

SPECIFICATION FOR APPROVAL

Customer:

Description: EC FAN

Customer P/N:

REV:

Delta Model NO.: GTW080NUT24R

Safety Model NO.:

Sample Rev: X00

Issue NO:

Sample Issue Date:

Quantity:

1. SCOPE:

THIS SPECIFICATION DEFINES THE ELECTRICAL AND MECHANICAL CHARACTERISTICS OF THIS AXIAL FAN .

2. NOMINAL DATA:

UNLESS SPECIFIED, ALL READINGS AND TESTS ARE BASED ON 25 DEG C, 65% RH.

ITEM	DESCRIPTION
NOMINAL VOLTAGE	3 ϕ 400 VAC 50/60Hz
NOMINAL VOLTAGE RANGE	3 ϕ 380 - 480 VAC
INPUT POWER @ FREE-AIR	1690 W
INPUT POWER @ MAX. LOAD	2200 W
INPUT CURRENT (MAX.)	3.43 A
SPEED	1020 R.P.M. (REF.)
MAX. AIR FLOW (AT ZERO STATIC PRESSURE)	26499 (MIN.23849) M ³ /H 15597 (MIN.14037) CFM
MAX. AIR PRESSURE	229.9 (MIN.186.2) Pa 0.923 (MIN.0.748) inchH ₂ O
ACOUSTICAL NOISE (AVG.) @ FREE-AIR	75 (Max. 80) dB(A)

- NOTES: 1. ALL READINGS ARE MEASURED AFTER STABLY WARMING UP THROUGH 10 MINUTES.
 2. THE VALUES WRITTEN IN PARENS , (), ARE LIMITED SPEC.
 3. ACOUSTICAL NOISE MEASURING CONDITION:

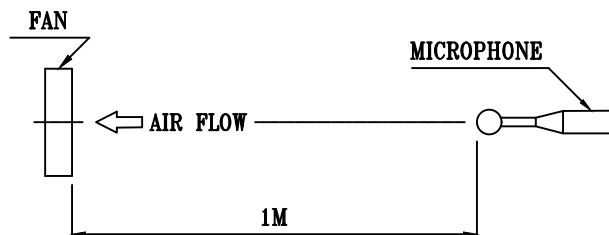

NOISE IS MEASURED AT NOMINAL VOLTAGE IN FREE AIR IN ANECHOIC CHAMBER WITH B & K SOUND LEVEL METER WITH MICROPHONE AT A DISTANCE OF ONE METER FROM THE FAN INTAKE.

PART NO:

DELTA MODEL: GTW080NUT24R

3. FEATURES:

DIRECTION OF ROTATION	COUNTER-CLOCKWISE, SEEN ON ROTOR
BEARING SYSTEM	BALL BEARINGS
WEIGHT	48.0 K.G. (REF.)
MATERIAL OF ELECTRONICS HOUSING	DIE-CAST ALUMINUM
MATERIAL OF IMPELLER	PPE+GF30
ELECTRICAL LEADS	VIA TERMINAL BLOCK
MOTOR PROTECTION	OVER TEMPERATURE PROTECTED
LEAKAGE CURRENT	<= 3.5 mA
INSULATION CLASS	F
TYPE OF PROTECTION	IP54
PROTECTION CLASS	I
POWER FACTOR CORRECTION	ACTIVE
OPERATING TEMPERATURE	-25~+60 °C (REF.)
STORAGE TEMPERATURE	-40~+70 °C (REF.)
EMC	* EN61000-6-2/3 , EN61000-3-2/3
SAFETY	* cUL, UL, TUV
LIFE EXPECTANCE	* 60,000 HOURS CONTINUOUS OPERATION AT 40 °C WITH 15 ~ 65 %RH.
FUNCTIONS	- CONTROL INPUT 0-10VDC or PWM PATTERN or 4-20mA - OUTPUT +10VDC(±10%), max. 10mA - CONTROL VOLTAGE OUTPUT, 0-10VDC - ALARM RELAY, LOCKED ROTOR PROTECTION, SOFT START - SPEED TELLING, FREQUENCY GENERATOR SIGNAL

PART NO:

DELTA MODEL: GTW080NUT24R

4. P & Q CURVE:

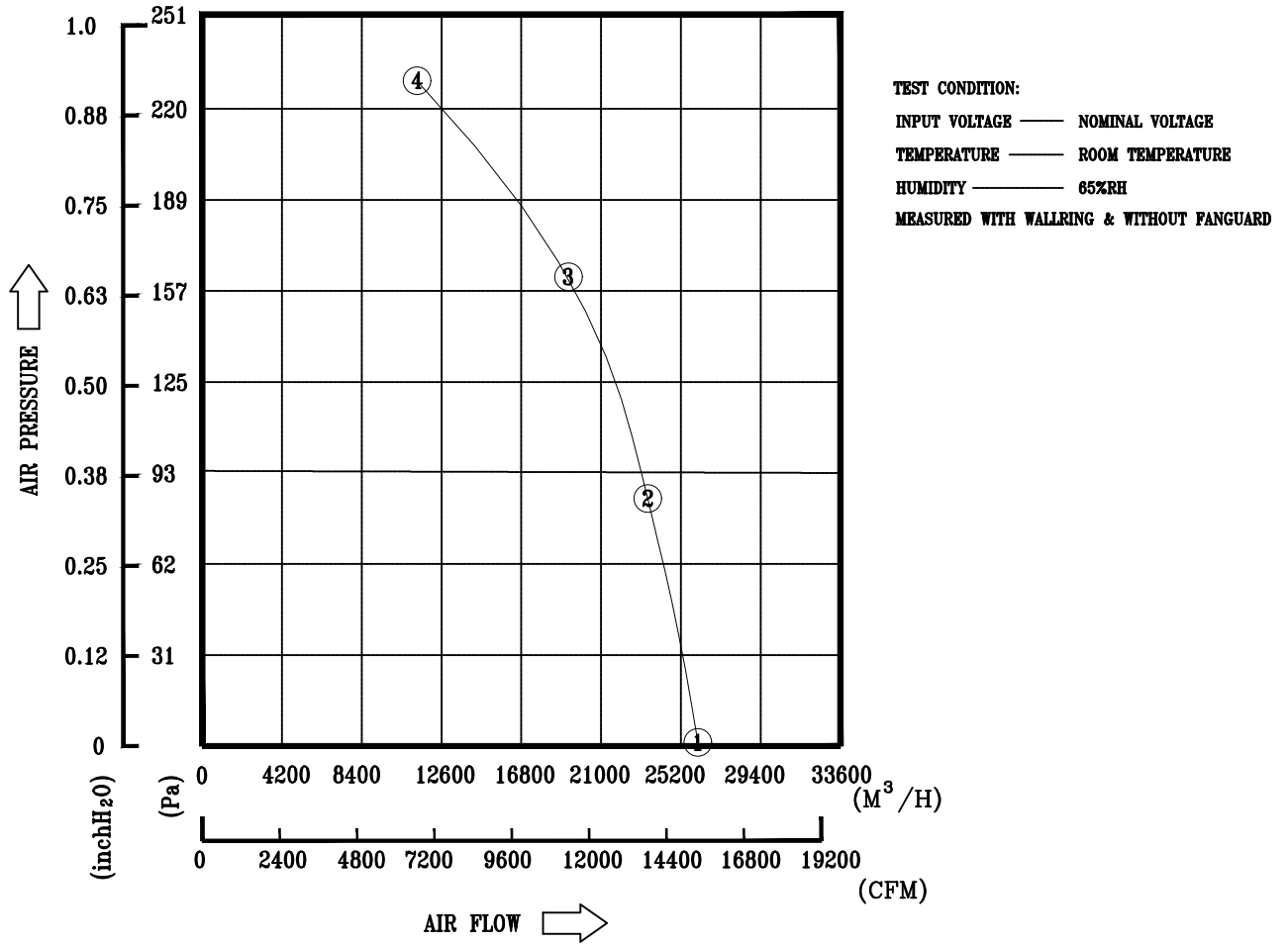

MEASURED DATA:

	P	Q	N	P1	I	Lp
	[Pa]	[M³/H]	[R.P.M.]	[W]	[A]	[dB(A)]
1	0	26499	1020	1694	2.61	75
2	84	23727	1020	1958	3.02	
3	166	19464	1020	2076	3.20	
4	230	11513	1020	2159	3.33	

PART NO:

DELTA MODEL: GTW080NUT24R

5. DIMENSION DRAWING: LABEL

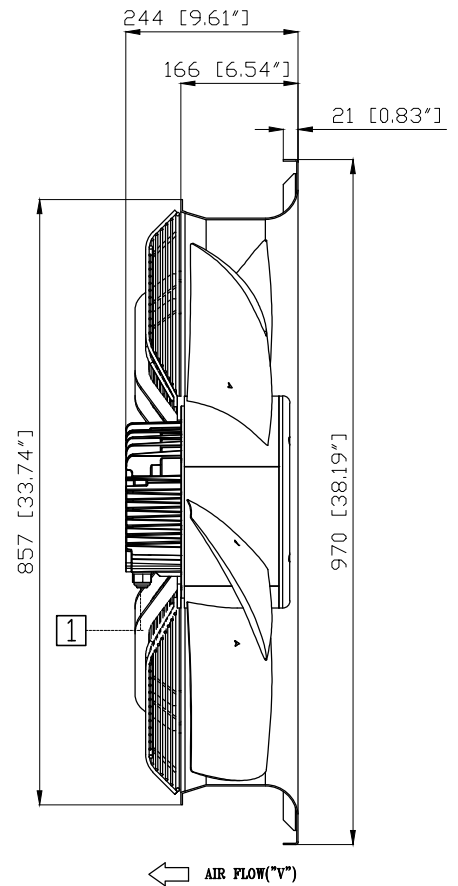
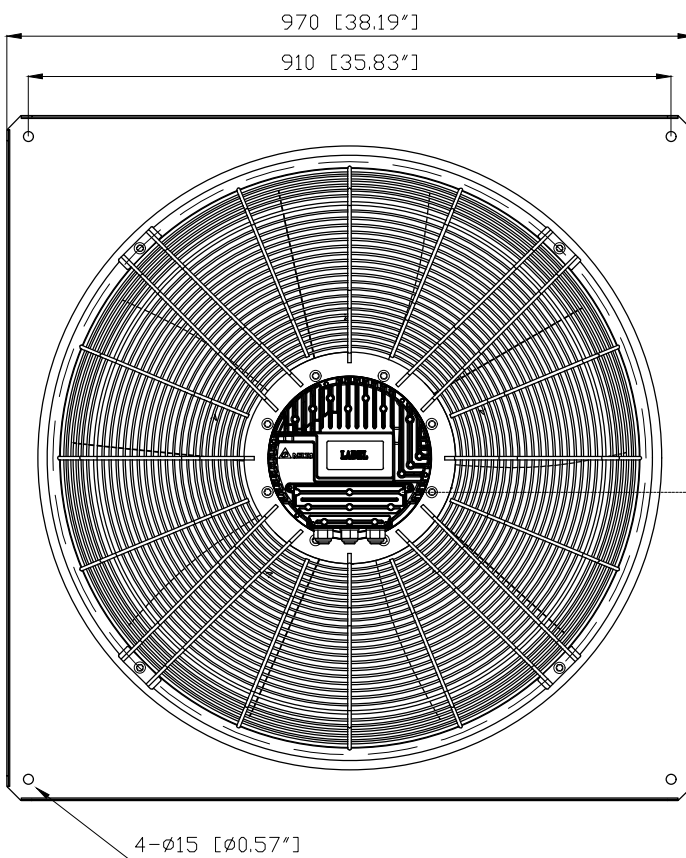

UNIT: mm[INCH]

NOTE:

- ① CABLE DIAMETER: ϕ 7.0~ ϕ 12.7mm.
- ② OPEN THE COVER AND REFER TO DEFINITION OF TERMINAL BLOCK.
- ③ THIS PRODUCT IS RoHS COMPLIANT.

PART NO:

DELTA MODEL: GTW080NUT24R

6. DEFINITION OF TERMINAL BLOCK:

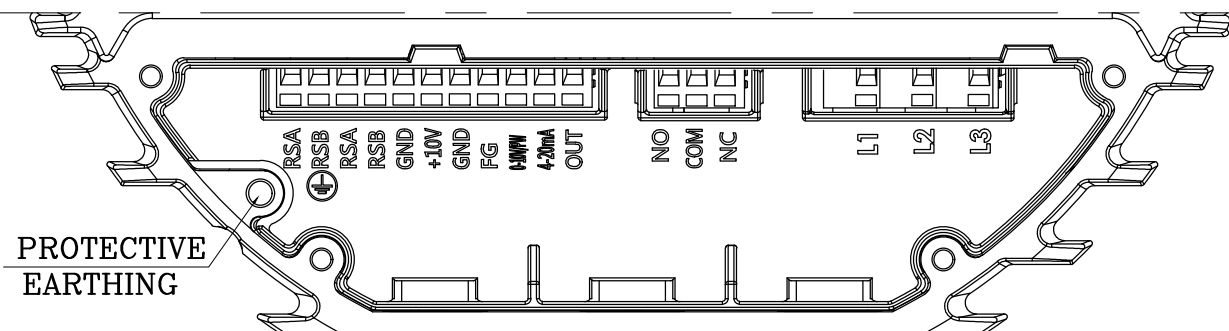

TEXT	FUNCTIONS
L1	AC MAINS
L2	AC MAINS
L3	AC MAINS
NO	ALARM RELAY, CLOSE BY RUNNING
COM	ALARM RELAY, COMMON(2A/250VAC)
NC	ALARM RELAY, CLOSE BY FAULT OR STOP
RSA	RS485-A
RSB	RS485-B
RSA	RS485-A
RSB	RS485-B
GND	GROUND
+10V	+10V OUTPUT, MAX 10mA (FOR EXTERNAL POTENTIOMETER)
GND	GROUND
FG	FREQUENCY GENERATOR (FG) SIGNAL
0-10V/PWM	SPEED CONTROL, INPUT 0-10VDC
4-20mA	SPEED CONTROL, INPUT 4-20mA
OUT	CONTROL VOLTAGE OUTPUT 0-10VDC (FOR EXTERNAL POTENTIOMETER)

PART NO:

DELTA MODEL: GTW080NUT24R

7. LEAD WIRE CONNECTION:

SPEED CONTROL APPLICATION
(CHOOSE ONE TO USE)

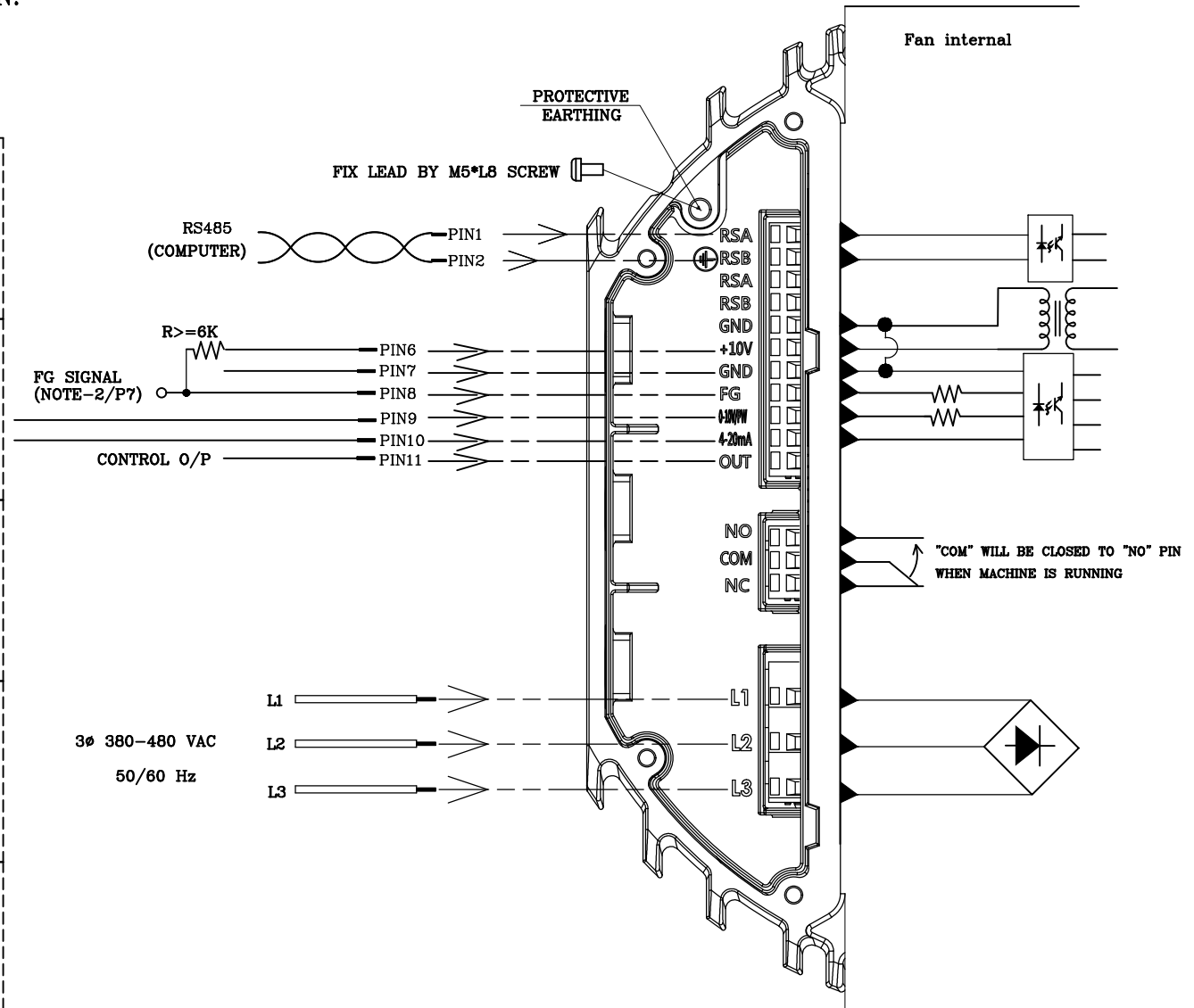
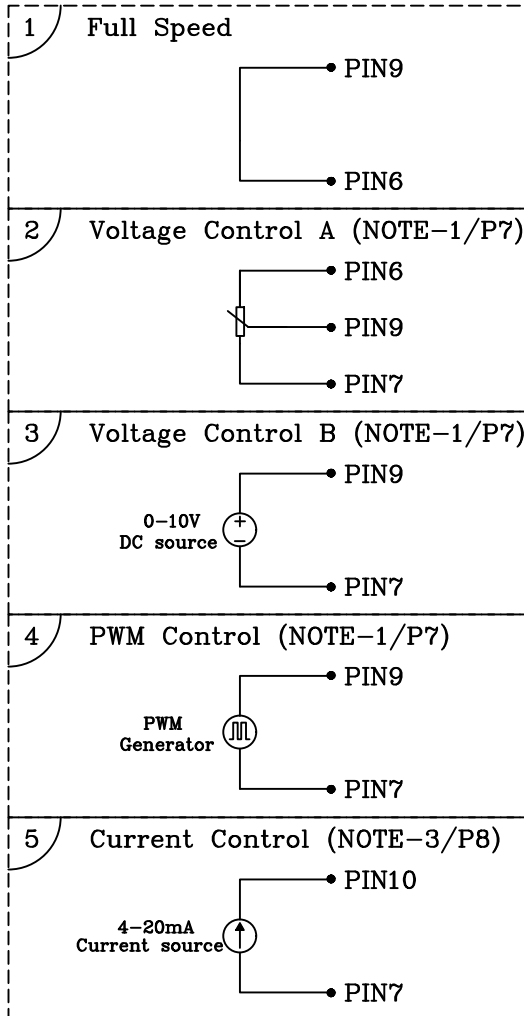

PART NO:

DELTA MODEL: GTW080NUT24R

8. SPEED CONTROL SIGNAL: VOLTAGE CONTROL *NOTE-1

- THERE ARE TWO WAYS TO CONTROL SPEED AND MUST OPEN 4-20mA INPUT.

A. VOLTAGE CONTROL

- CONTROL VOLTAGE RANGE SHALL BE 0-10 VDC.
- VOLTAGE HIGHER 9.0VDC, THE FAN WILL SPIN AT MAXIMUM SPEED.
- VOLTAGE HIGHER THAN 1.5 VDC, THE FAN WILL START UP.
- VOLTAGE LOWER THAN 0.5 VDC, THE FAN WILL STOP.

B. PWM CONTROL

- THE AMPLITUDE VOLTAGE SHALL BE 10VDC. (100Hz~100kHz)

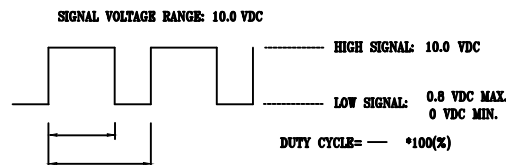

- PWM DUTY HIGHER THAN 15 % , THE FAN WILL START UP.
- PWM DUTY LOWER THAN 5 % , THE FAN WILL STOP.

- THE SPEED COMPARISON WITH CONTROL LEVEL:

VOLTAGE(V)	PWM DUTY(%)	SPEED (R.P.M.) (REF.)
0.0	0	0
2.0	20	127
9.5	95	1020

*NOTE-2: FREQUENCY GENERATOR (FG) SIGNAL

$V_{CE} \text{ (sat)} = 0.7V \text{ MAX.}$

$V_{FG} = 20.0V \text{ MAX.}$

$I_c = 5mA \text{ MAX.}$

$R \geq V_{FG} / I_c$

FREQUENCY GENERATOR WAVEFORM

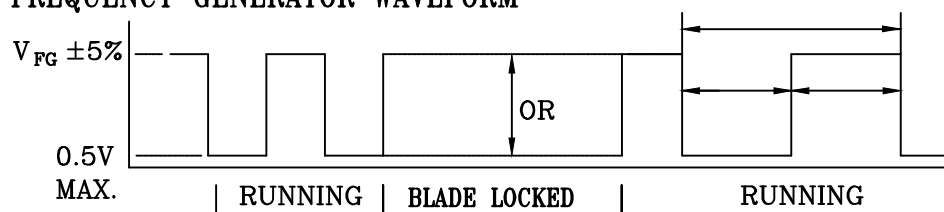

$N = \text{R.P.M}$	1 PULSE PER REVOLUTION
$TS = 60 / N(\text{SEC})$	$T1 = T2 = 1/2 TS$

PART NO:

DELTA MODEL: GTW080NUT24R

9. SPEED CONTROL SIGNAL: CURRENT CONTROL *NOTE-3

- SPEED CAN BE CONTROLLED BY CURRENT LEVEL AND MUST OPEN 0-10V/PWM INPUT.
 - CONTROL VOLTAGE RANGE SHALL BE 4.0-20 mA.
 - CURRENT HIGHER THAN 19.0 mA, THE FAN WILL SPIN AT MAXIMUM SPEED.
 - CURRENT HIGHER THAN 6.0 mA, THE FAN WILL START UP.
 - CURRENT LOWER THAN 4.5 mA, THE FAN WILL STOP.

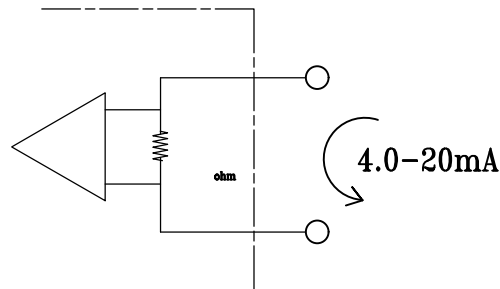

- THE SPEED COMPARISON WITH CONTROL LEVEL:

CURRENT(mA)	SPEED (R.P.M.) <small>(REF.)</small>
4.0	0
7.0	127
14.0	640
19.5	1020

PART NO:

DELTA MODEL: GTW080NUT24R

10. CONTROL VOLTAGE(PWM DUTY) & SPEED CURVE:
(SPEED CONTROL PIN)

