



SPECIFICATION FOR APPROVAL

Customer : STD

Description : DC FAN

Customer Part No. _____

REV. : _____

Delta Model No. : AFB1212EJ-01

REV. : 00

Sample Issue No. : _____

Sample Issue Date : OCT.18 2022

PLEASE SEND ONE COPY OF THIS SPECIFICATION BACK AFTER YOU SIGNED APPROVAL FOR PRODUCTION PRE-ARRANGMENT.

APPROVED BY:

DATE :

DELTA ELECTRONICS, INC.
HeTianXia High-Tech Industrial Park.
Shi Jie Town, Dong Guan City.
Guangdong Province, China. P. R. C.
TEL : 86-769-86329008
FAX : 86-769-86631589

DELTA ELECTRONICS, INC
HeTianXia High-Tech Industrial Park.
Shi Jie Town, Dong Guan City.
Guangdong Province, China. P. R. C.

TEL : 86-769-86329008
FAX : 86-769-86631589

STATEMENT OF DEVIATION

NONE

DESCRIPTION:

DELTA ELECTRONICS, INC
HeTianXia High-Tech Industrial Park.
Shi Jie Town, Dong Guan City.
Guangdong Province, China. P. R. C.

TEL : 86-769-86329008
FAX : 86-769-86631589

Specification For Approval

Customer : STD

Description : DC FAN

Customer P/N :

rev. :

Delta model no. : AFB1212EJ-01

Delta Safety Model No.: AFB1212EJ-01

Sample revision. : 00

Issue no.:

Sample issue date : OCT.18 2022

Quantity :

1. SCOPE:

2. CHARACTERS:

ITEM	DESCRIPTION
RATED VOLTAGE	12 VDC
OPERATION VOLTAGE	10.8 - 12.6 VDC
INPUT CURRENT (AVG) #	1.10 (MAX. 1.32) A SAFETY CURRENT ON LABEL: 1.50A
RATED POWER (AVG)	13.20 (MAX 15.84) W
SPEED	4500 ± 10% R.P.M.
MAX. AIR FLOW (AT ZERO STATIC PRESSURE)	4.117 (MIN. 3.706) M ³ /MIN. 145.40 (MIN. 130.86) CFM
MAX. AIR PRESSURE (AT ZERO AIRFLOW)	18.381 (MIN. 14.889) mmH ₂ O 0.724 (MIN. 0.586) inchH ₂ O
ACOUSTICAL NOISE (AVG.)	58.5 (MAX. 62.5) dB-A
INSULATION TYPE	UL: CLASS A

: THE MAX VALUE OF CONSUMING CURRENT DOES NOT REPRESENT THE PEAK VALUE,
THE PEAK VALUE NEED MEASURE BY OSCILLOSCOPE.

(continued)

PART NO:

DELTA MODEL: AFB1212EJ-01

INSULATION STRENGTH	10 MEG OHM MIN. AT 500 VDC (BETWEEN FRAME AND (+) TERMINAL)
DIELECTRIC STRENGTH	5 mA MAX. AT 500 VAC 50/60 Hz ONE MINUTE, (BETWEEN FRAME AND (+) TERMINAL)
LIFE EXPECTANCE (L10) (AT LABEL VOLTAGE)	70,000 HOURS CONTINUOUS OPERATION AT 40 ° C WITH 15 ~ 65 %RH.
ROTATION	CLOCKWISE VIEW FROM NAME PLATE SIDE
LOCKED ROTOR PROTECTION	THE CURRENT WILL SHUT DOWN, WHEN ROTOR LOCKED AND FIXED.

NOTES:

1. ALL READINGS ARE MEASURED AFTER STABLY WARMING UP THROUGH 10 MINUTES.
2. STANDARD AIR PROPERTY IS AIR AT (Td) 25°C TEMPERATURE, (RH) 65% RELATIVE HUMIDITY , AND (Pb) 760 mmHg BAROMETRIC PRESSURE.
3. THE VALUES WRITTEN IN PARENS , (), ARE LIMITED SPEC.
4. THE CHARACTERS SHOWED IN PAGE 1 IS THE CONDITION OF BOTH FANS RUN.
5. ACOUSTICAL NOISE MEASURING CONDITION:

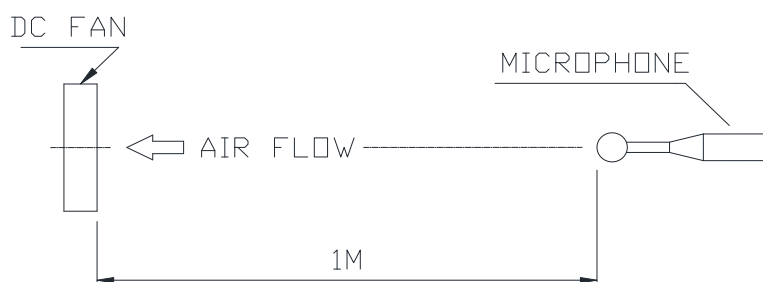

NOISE IS MEASURED AT RATED VOLTAGE IN FREE AIR IN SEMI-ANECHOIC CHAMBER WITH MICROPHONE AT A DISTANCE OF ONE METER FROM THE FAN INTAKE.

PART NO:

DELTA MODEL: AFB1212EJ -01

3. MECHANICAL:

- 3-1. DIMENSIONS----- SEE DIMENSIONS DRAWING
- 3-2. FRAME----- PLASTIC UL: 94V-0
- 3-3. IMPELLER----- PLASTIC UL: 94V-0
- 3-4. BEARING SYSTEM----- TWO BALL BEARINGS
- 3-5. WEIGHT----- 190 GRAMS(REF.)

4. ENVIRONMENTAL:

- 4-1. OPERATING TEMPERATURE----- -10 TO +60 DEGREE C
- 4-2. STORAGE TEMPERATURE----- -40 TO +70 DEGREE C
- 4-3. OPERATING HUMIDITY----- 5 TO 90 % RH
- 4-4. STORAGE HUMIDITY----- 5 TO 95 % RH

5. PROTECTION:

- 5-1. LOCKED ROTOR PROTECTION
IMPEDANCE OF MOTOR WINDING PROTECTS MOTOR FROM FIRE IN
96 HOURS OF LOCKED ROTOR CONDITION AT THE RATED VOLTAGE.
- 5-2. POLARITY PROTECTION
BE CAPABLE OF WITHSTANDING IF REVERSE CONNECTION FOR
POSITIVE AND NEGATIVE LEADS.

6. RE OZONE DEPLETING SUBSTANCES:

- 6-1. NO CONTAINING PBBs, PBBOs, CFCs, PBBEs, PBDPEs AND HCFCs.

7. PRODUCTION LOCATION

- 7-1. PRODUCTS WILL BE PRODUCED IN CHINA OR THAILAND.

PART NO:

DELTA MODEL: AFB1212EJ -01

8. P & Q CURVE:

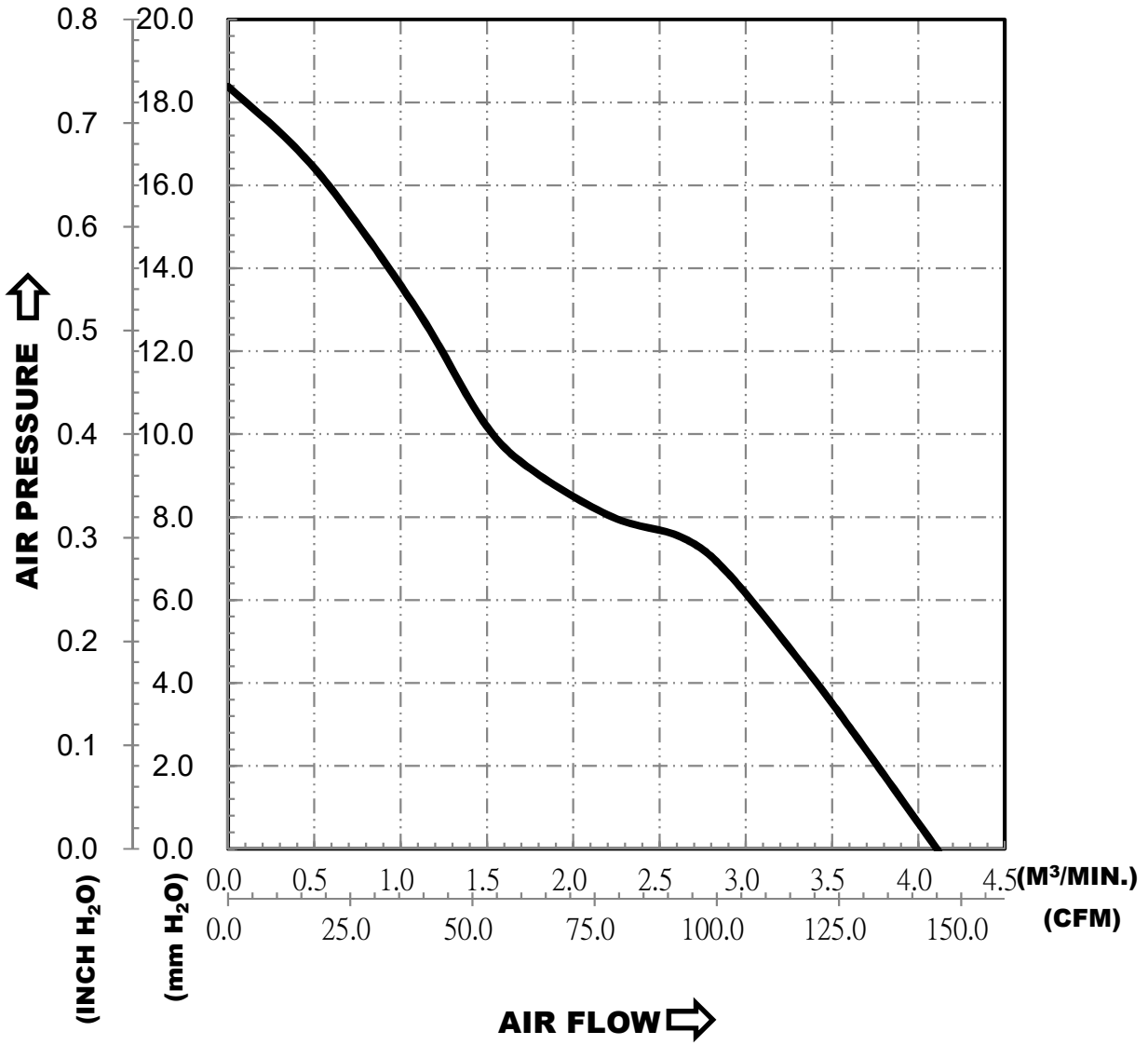

*TEST CONDITION: INPUT VOLTAGE-----OPERATION VOLTAGE
TEMPERATURE-----ROOM TEMPERATURE
HUMIDITY-----65%RH

PART NO:

DELTA MODEL: AFB1212EJ-01

9. DIMENSION DRAWING:

LABEL:

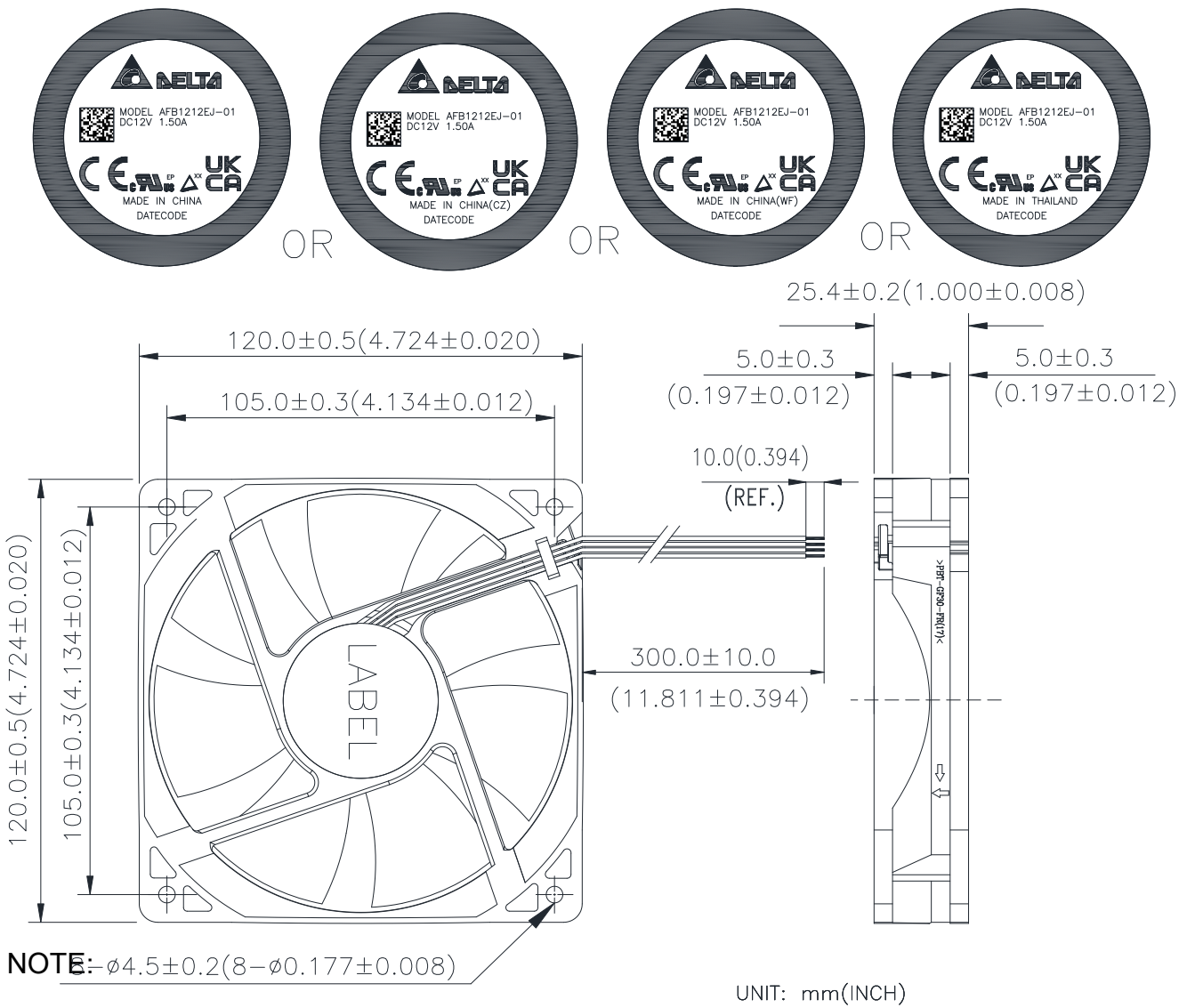

1. LEAD WIRE UL:1061 AWG#26
BLACK WIRE-----(-)
RED WIRE-----(+)
YELLOW WIRE---(PWM)
BLUE WIRE-----(FG)
2. THIS PRODUCT IS RoHS COMPLIANT.

PART NO:

DELTA MODEL: AFB1212EJ-01

12. PWM CONTROL SIGNAL:

SIGNAL VOLTAGE RANGE: 0~5.0VDC

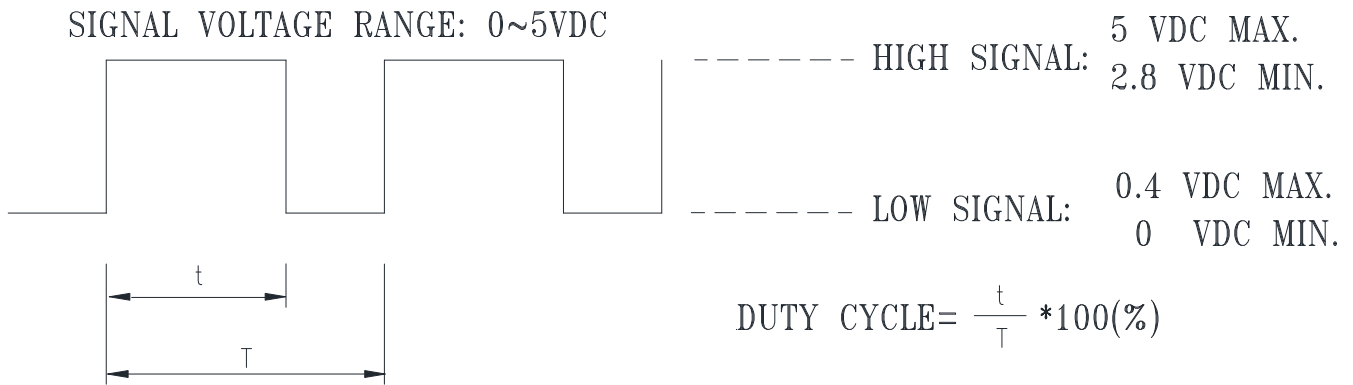

*THE PREFERRED OPERATING POINT FOR THE FAN IS 25KHZ.

*AT 100% DUTY CYCLE, THE ROTOR WILL SPIN AT MAXIMUM SPEED.

*AT 0% DUTY CYCLE, THE ROTOR WILL SPIN AT MINIMUM SPEED.

*WITH CONTROL SIGNAL LEAD DISCONNECTED, THE FAN WILL SPIN AT MAXIMUM SPEED.

13. SPEED VS PWM CONTROL SIGNAL:

(AT 25°C, Vcc=12VDC & PWM FREQUENCY=25KHZ)

DUTY CYCLE (%)	SPEED R.P.M.	CURRENT (A) TYP.
100	4500±10%	1.10(MAX. 1.32)
0-20	500±300	0.05(MAX.0.07)

*PWM SIGNAL
PWM FREQUENCY = 25KHz

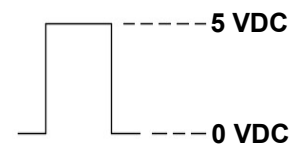

14. PWM CONTROL LEAD WIRE INPUT IMPEDANCE:

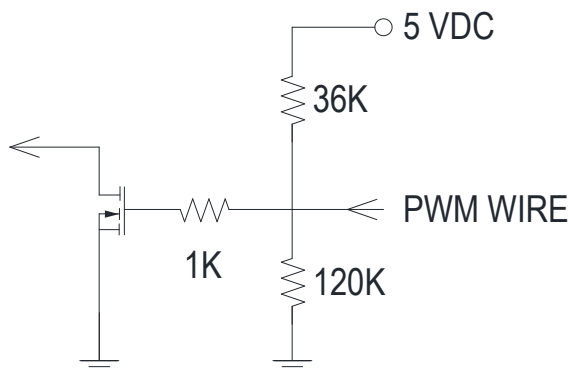

PART NO:

DELTA MODEL: AFB1212EJ-01

15. SCREW SPECIFICATION:

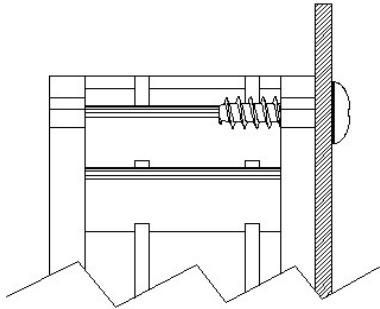

SELF-TAPPING SCREW
FLANGE MOUNTING DRAWING



FLANGE TYPE

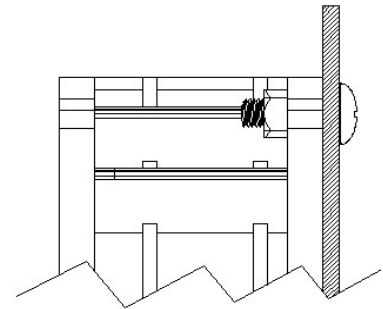

MECHANICAL SCREW
FLANGE MOUNTING DRAWING

DEPTH 6~8mm FOR MOUNTING HOLE $\phi 3.5$
DEPTH 7~10mm FOR MOUNTING HOLE $\phi 4.3/4.5$

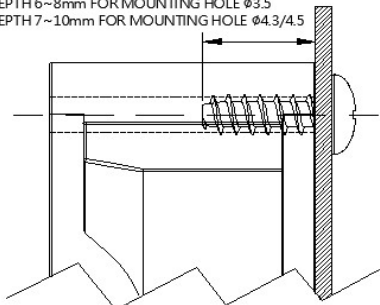

SELF-TAPPING SCREW
RIB MOUNTING DRAWING



RIB TYPE(ALL RIB)



RIB TYPE(HALF FLANGE & HALF RIB)

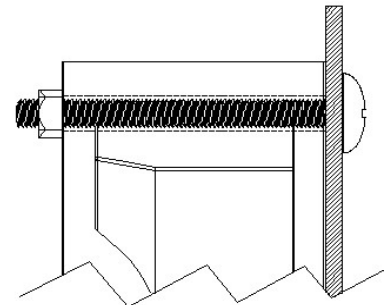

MECHANICAL SCREW
RIB MOUNTING DRAWING

NOTE:

- 1.SELF-TAPPING SCREW ACCORDING TO JIS B 1122 TYPE 2
- 2.EACH SCREW HOLE CAN ONLY TIGHTENED ONCE WHEN USING SELF-TAPPING SCREW .
- 3.IF IT WAS SLIPPAGE OR BREAK WHEN TIGHTENED SELF-TAPPING SCREW,
THEN CAN USING LOWER TORQUE THAN WE RECOMMENDED IN TABLE A .

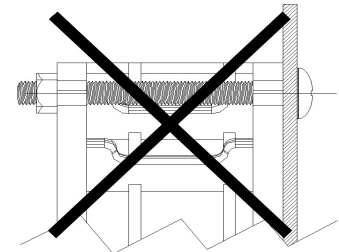

MECHANICAL SCREW
FLANGE MOUNTING DRAWING

TABLE A: MOUNTING HOLE WITH RECOMMENDED SCREW

* FOLLOW JIS B 1007

FAN TYPE	MOUNTING HOLE DIAMETER	SCREW TYPE	SCREW SPEC.	SCREW OUTER DIMENSION. (mm)		RECOMMENDED MAX. TORQUE (kgf-cm)	
				MAXIMUM	MINIMUM	FLANGE TYPE	RIB TYPE
<input type="checkbox"/>	FLANGE	SELF-TAPPING	ST3.5*1.3	3.53	3.35	4.5	5.5
<input type="checkbox"/>	RIB						
<input type="checkbox"/>	FLANGE	MECHANICAL	M3.0x0.5	2.98	2.88	4.5	7.5
<input type="checkbox"/>	RIB						
<input type="checkbox"/>	FLANGE	SELF-TAPPING	*ST4.0x1.41	4	3.85	5.5	
<input type="checkbox"/>	RIB						
<input type="checkbox"/>	FLANGE	MECHANICAL	M3.0x0.5	2.98	2.88	4.5	
<input type="checkbox"/>	RIB						
<input type="checkbox"/>	FLANGE	SELF-TAPPING	*ST4.8x1.6	4.8	4.62	5.5	
<input type="checkbox"/>	RIB						
<input checked="" type="checkbox"/>	FLANGE	SELF-TAPPING	*ST5.0x1.59	5	4.85	5.5	
<input type="checkbox"/>	RIB						
<input type="checkbox"/>	FLANGE	MECHANICAL	M4x0.7	3.97	3.84	4.5	
<input type="checkbox"/>	RIB						



Application Notice

- 1. Delta will not guarantee the performance of the products if the application condition falls outside the parameters set forth in the specification.**
- 2. A written request should be submitted to Delta prior to approval if deviation from this specification is required.**
- 3. Please exercise caution when handling fans. Damage may be caused when pressure is applied to the impeller, if the fans are handled by the lead wires, or if the fan was hard-dropped to the production floor.**
- 4. Except as pertains to some special designs, there is no guarantee that the products will be free from any such safety problems or failures as caused by the introduction of powder, droplets of water or encroachment of insect into the hub.**
- 5. The above-mentioned conditions are representative of some unique examples and viewed as the first point of reference prior to all other information.**
- 6. It is very important to establish the correct polarity before connecting the fan to the power source. Positive (+) and Negative (-). Damage may be caused to the fans if connection is with reverse polarity, if there is no foolproof method to protect against such error specifically mentioned in this spec.**
- 7. Delta fans without special protection are not suitable where any corrosive fluids are introduced to their environment.**
- 8. Please ensure all fans are stored according to the storage temperature limits specified. Do not store fans in a high humidity environment. We highly recommend performance testing is conducted before shipping, if the fans have been stored over 6 months.**
- 9. Not all fans are provided with the Lock Rotor Protection feature. If you impair the rotation of the impeller for the fans that do not have this function, the performance of those fans will lead to failure.**
- 10. Please be cautious when mounting the fan. Incorrect mounting of fans may cause excess resonance, vibration and subsequent noise.**
- 11. It is important to consider safety when testing the fans. A suitable fan guard should be fitted to the fan to guard against any potential for personal injury.**
- 12. Except where specifically stated, all tests are carried out at room (ambient) temperature and relative humidity conditions of 25°C, 65% RH. The test value is only for fan performance itself.**
- 13. Be certain to connect an “ 4.7µF or greater” capacitor to the fan externally when the application calls for using multiple fans in parallel, to avoid any unstable power.**