



## Specification For Approval

Customer			
Description	EC fan		
Customer Part number			
Delta Model Number	GTMA45PBV39R		
Safety Model Number			
Issue Date	2025/04/29	Version	00

Please send one copy of this specification back after you signed approval for production pre-arrangement

Approved by :

\_\_\_\_\_

Date :

\_\_\_\_\_

# Electronically Commutated (EC) Fan

Centrifugal Fan  
600 x 600 x 463 mm

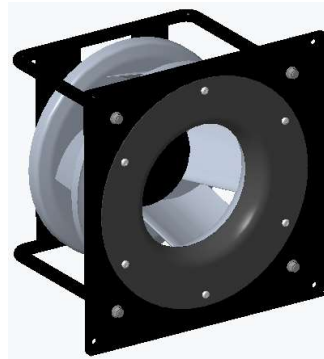

## DELTA ELECTRONICS, INC.

No.252, Shangying Road, Guishan Industrial Zone, Taoyuan City, 33341, Taiwan

TEL: +886-3-359-1968

FAX: +886-3-359-1991

[www.deltaww.com](http://www.deltaww.com)



## Technical features

Input Power		Mechanics	
Nominal Voltage	3~400Vac, 50/60Hz	Rotation Direction	<input checked="" type="checkbox"/> CW <input type="checkbox"/> CCW , Seen on rotor
Voltage Range	3~380Vac-480Vac	Weight	50 Kg
Power@ Free air / Max Load	2649W / 4500W	Electrical Leads	<input type="checkbox"/> Cable <input checked="" type="checkbox"/> Via terminal block
Max. Current	7.20A	Bearing System	Maintain-free ball bearings
Fan Performance		Residual Balance	G2.5 (ISO1940)
Max. Rotation Speed	2430RPM	Vibration	BV-3 (ISO14694)
Max. Airflow (Qmax)	14036 CMH / 8257 CFM	Environment	
Max. Air pressure (Pmax)	1828 Pa / 7.34 inAq	Operating Range	-25~+60 °C, 0~95%RH
Noise @ Qmax (Lp@1m inlet)	90.0	Storage Range	-40~+70 °C, 0~70%RH
Control Signals		Ingress Protection	IP55
0-10V <sub>DC</sub> / PWM / Current 0-20mA		Life (L10)	60,000 hrs@40 °C, 15~65 %RH
RS485 control bus		Altitude	<1,000m
Output Signals		Regulations	
Output +10V <sub>DC</sub> (±10%), max. 10mA		Safety Approval	<input type="checkbox"/> UL/cUL <input type="checkbox"/> CE <input type="checkbox"/> UKCA <input type="checkbox"/> CCC <input type="checkbox"/> AMCA
Voltage / Current monitoring / Alarm relay		EMS (immunity)	EN61000-6-2
Protections / Functions		- Surge immunity	L-L 2KV,2Ω / L-PE 4KV,12Ω
Locked rotor protection		EMI (emission)	EN61000-6-3
Abnormal voltage protection		- Conducted emission	CISPR 16 Class B
Over temperature protection		- Radiated emission	CISPR 16 Class B
Initiating start-up while in reverse rotation < 500rpm		PFC	Passive
Soft Start ( 0 to 100% speed around 30 Secs )		Protection Class	Class I equipment (EN 61140)
		Leakage Current	Lower than 3.5 mA (IEC60990)
		Motor Insulation Class	Class F (155°C)
		ErP Directive	(EU) No 327/2011 (Erp 2015)

Delta reserves the right to change specifications and other product information without prior notice.

P & Q curves

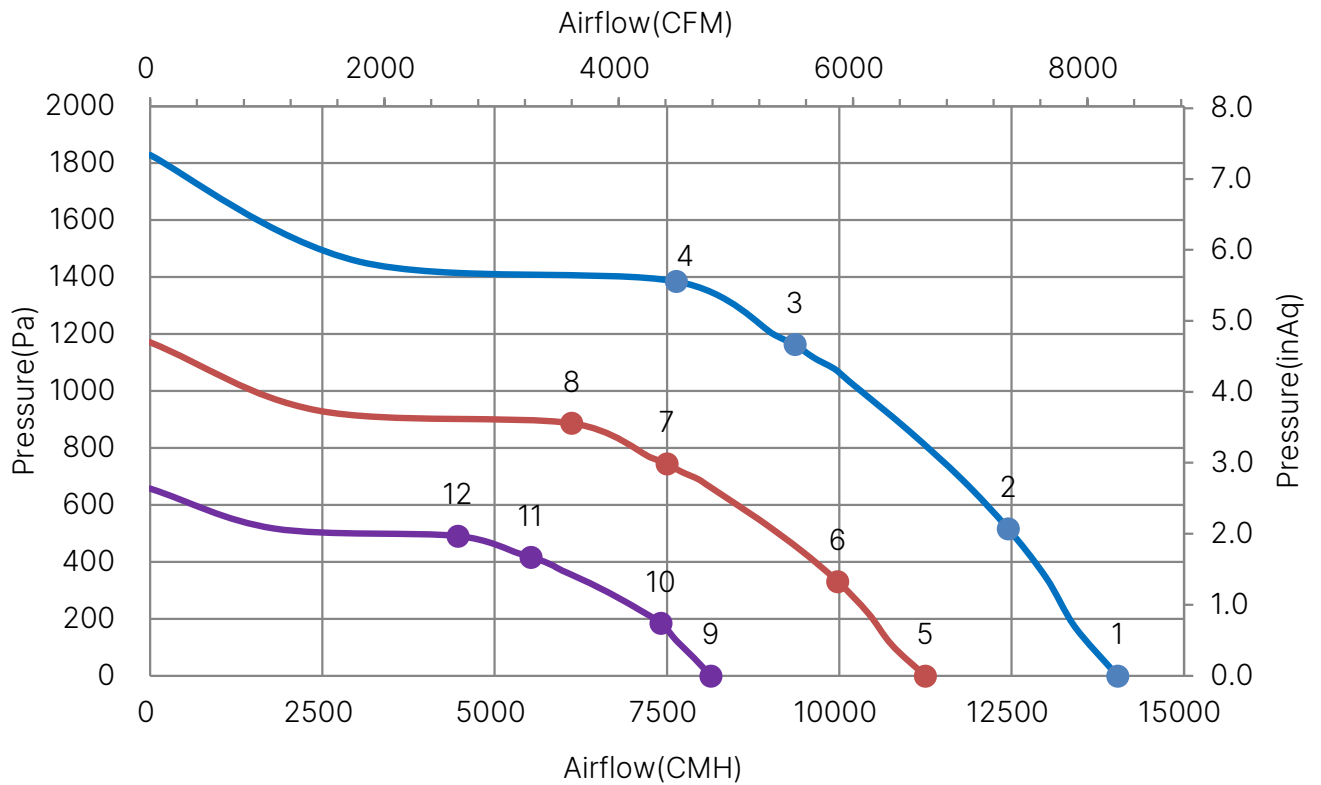

	P	Q	N	P1	I	Lp	Erp Directive		
	[Pa]	[CMH]	[R.P.M.]	[W]	[A]	[dB(A)]	Actual	Req. Erp2015	
1	0	14036	2430	2649	4.2	90.0	Overall Eff (%)	69.7	58.3
2	517	12448	2430	3664	5.9		Eff. Grade N	73.3	62
3	1164	9353	2430	4475	7.2		Power (kW)	4.475	
4	1385	7630	2430	4500	7.2		Air Flow (CMH)	9353	
5	0	11248	1945	1359	2.2	82.0	Pressure (Pa)	1164	
6	331	9975	1945	1879	3.0		Speed (RPM)	2430	
7	745	7495	1945	2295	3.7				
8	887	6114	1945	2310	3.7				
9	0	8134	1455	591	0.9	70.5			
10	185	7409	1455	797	1.3				
11	416	5521	1455	967	1.6				
12	491	4462	1455	978	1.6				

**Test Condition :**

Test method refers to ISO5801 (air density of 1.15 kg/m<sup>3</sup> )  
 Input Voltage : Nominal Voltage  
 Noise (Lp) is measured at a distance of one meter from the inlet side.

Dimension Drawing

Label



Fan

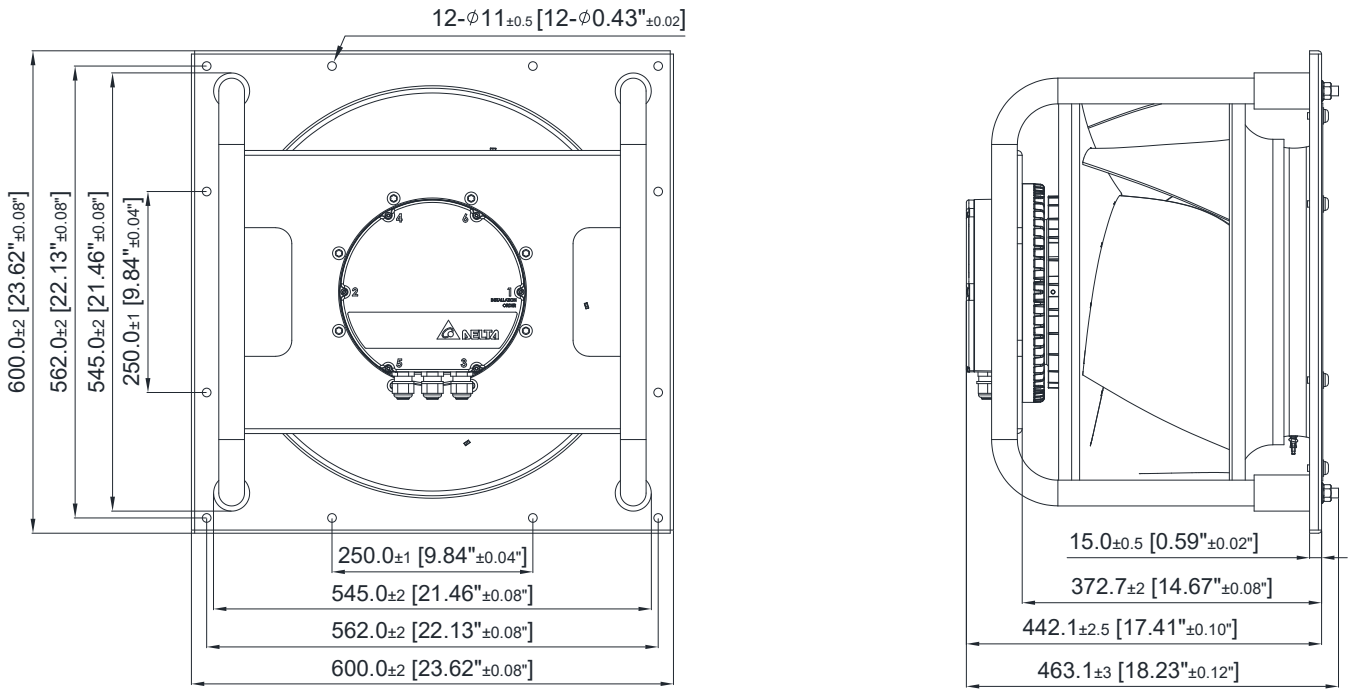

UNIT: mm[INCH]

Note :

1. With 3 Cable Glands (M20 x 1.5), Please refer to the Appendix for details regarding the suitable cable diameter and screw torque.
2. Materials :

Impeller	Aluminum Sheet
Motor electrical housing	Aluminum
Motor wiring cover	Aluminum
Bracket	Steel sheet and pipe with painting
Nozzle	Steel with painting

## Definition of terminal box

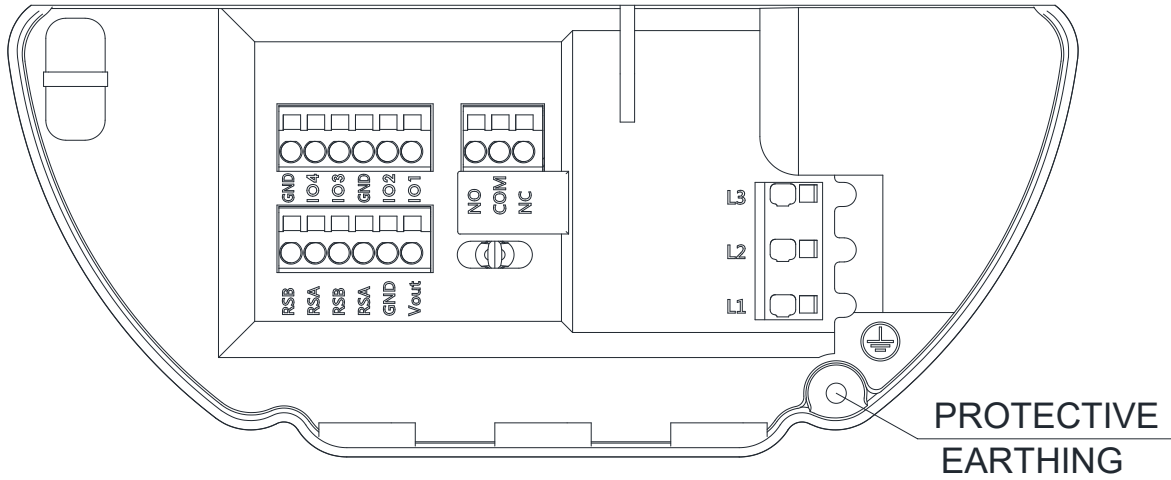

	Text	Functions		
Power	L1	AC main (3~ 380-480VAC)		
	L2	AC main (3~ 380-480VAC)		
	L3	AC main (3~ 380-480VAC)		
Status	COM	Alarm relay (2A/250VAC)	NC-COM	Normal
	NC			Close
I/O Signals	RSB	RS485-B		
	RSA	RS485-A		
	RSB	RS485-B		
	RSA	RS485-A		
	GND	Ground		
	Vout	+3.3-24V/800mW output (default: +10V)		
	GND	Ground		
	IO4	Control voltage output 0-10VDC		
	IO3	Speed control, input 0-10VDC/PWM		
GND	Ground			
	IO2	Speed control, input 4-20mA		
	IO1	Frequency generator (FG) signal		

Wire end condition	Power	Status & IO
Wire stripping length	13mm	9mm
AWG	10-24	12-26
Solid conductor	0.2-4mm <sup>2</sup>	0.2-2.5 mm <sup>2</sup>
Stranded conductor	0.2-4mm <sup>2</sup>	0.2-2.5 mm <sup>2</sup>
Ferrule without insulation	0.25-4mm <sup>2</sup>	0.25-2.5 mm <sup>2</sup>
Ferrule with insulation	0.25-4mm <sup>2</sup>	0.25-1.5 mm <sup>2</sup>
operation screwdriver head size 0.5mmx3mm		
* Please note the range provided only takes into account the compatibility between the terminal and wire. Users should also consider the current limitation associated with usage scenarios to ensure safety.		

Control and Signals

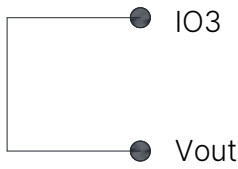
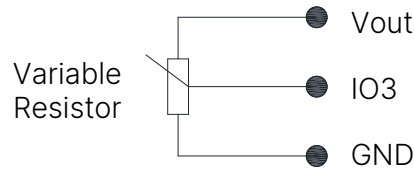
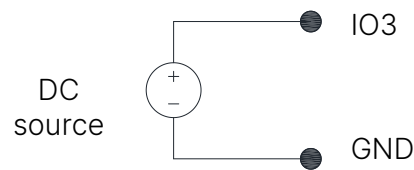
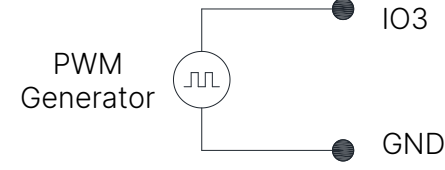
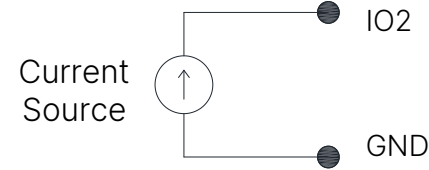
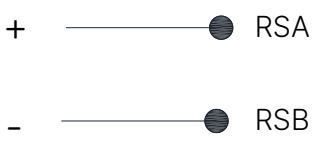
Diagram	Note
<p><b>Full speed control</b></p> 	<p>By shorting Vout &amp; IO3, the fan will run at full speed.</p>
<p><b>Variable resistor control</b></p> 	<p>Connect a 1-10kΩ variable resistor between Vout with GND and IO 3 (0-10V/PWM). The fan speed can be controlled by adjusting the resistance of the variable resistor.</p>
<p><b>Voltage control</b></p> 	<p>Employ a 0~10V<sub>DC</sub> source DC+ connect to IO 3 (+) DC- connect to GND (-) The fan speed can be controlled by voltage.</p>
<p><b>PWM duty control</b></p> 	<p>Employ a PWM generator amplitude 3.3~24V<sub>DC</sub>, frequency range 100Hz~100kHz The fan speed can be controlled by varying the PWM duty. -PWM duty higher than 15%, fan start up -PWM duty lower than 5%, fan stop</p>
<p><b>Current control</b></p> 	<p>Employ a 4~20mA current generator I+ connect to (IO2) I- connect to GND (-) Leave 0-10V/PWM PIN open - 4.0 mA → Fan Stop - 6.0 mA → Fan Start up - 19.5 mA → Maximum Speed</p>
<p><b>RS485 control</b> (can be used for status monitor purpose only)</p> 	<ul style="list-style-type: none"> <li>Control mode selection (speed, fixed speed or fixed PWM duty)</li> <li>Speed and power consumption monitor</li> <li>Multiple FANs control and status patrol</li> </ul> <p>*To ensure better communication quality, shielded MODBUS over Serial Line Cable is required. At one end of each cable, its shield must be connected to protective ground.</p>

Control Curve

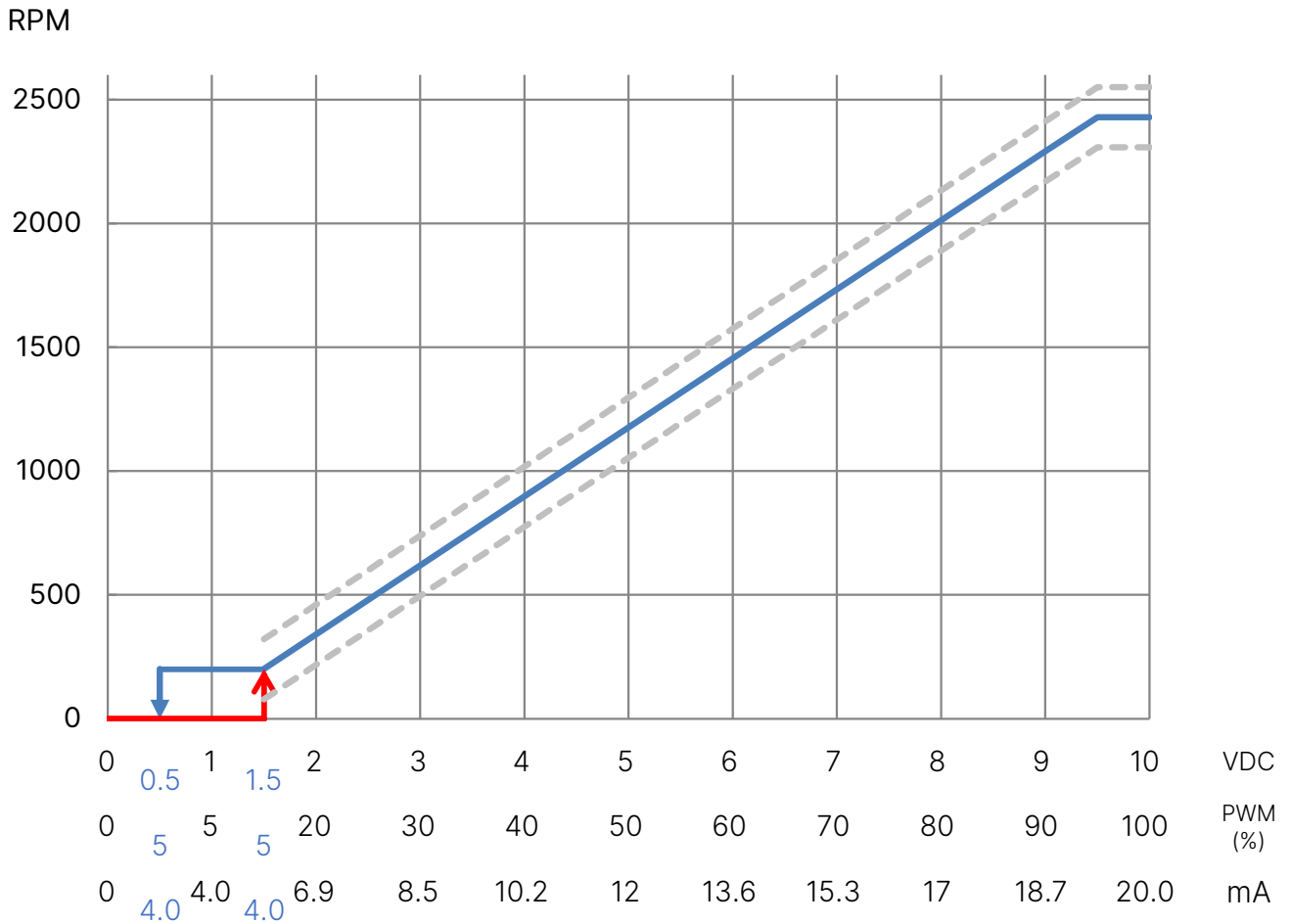

**Note:**

rpm tolerance,  $\pm 5\%$  of maximum speed

If the fan operates under the following situations, its speed may drop below the specified lower bound:

1. When the input voltage is lower than the rated range.
2. If the fan's power reaches its maximum limit.
3. When the surrounding temperature exceeds the specified limit.

## Appendix : Safety Instruction



### Attention!!

**Please carefully read and follow the instructions to ensure the correct installation and operation of the fan and to prevent any damage to personnel or machinery.**

### Scope to use

- The fan is intended solely for air movement and heat dissipation within the system and should not be utilized for any other purposes. Please refrain from using it outside of the designated system.
- **Avoid using the fan in the following scenarios unless the specifications sheets specifically meet the requirement.**
  - a. Environments prone to corrosion, flammable gases and liquids, floating dust, and metal particles.
  - b. Environments experiencing significant vibrations during transportation and installation.
  - c. Medical equipment or equipment vital for life safety.

### Basic safe regulation

- Only qualified professional staff are permitted to install, repair, and maintain the fan. Non-technical individuals should be prevented from undertaking these actions.
- If the fan exceeds 10 kg in weight, it is recommended to have it handled by two persons or to utilize a lifting machine for its movement and installation.
- Modification of internal parts or circuits of the fan by oneself, as well as disassembling the fan into separate components for individual use, is strictly prohibited.
- Applying additional painting or coating onto the fan is prohibited.
- Improper installation may result in damage to the fan.
- It is necessary to perform routine maintenance checks.

### Safety check

#### Risk of electric shock

- If defects are detected in the connecting components or cables during installation or routine inspections, it is crucial to replace them promptly.
- When working with live equipment, please ensure to stand on an insulated surface, such as a rubber mat or wear insulating shoes, to reduce the risk of electric shock.
- Before conducting maintenance, please ensure to switch off the fan power and wait for five minutes to allow complete discharge, minimizing the risk of electric shock.
- Although the fan body features basic insulation protection, there remains a potential risk of electrification under abnormal conditions. It is advisable to use testing instruments to verify safety before operation.
- If the fan body is equipped with a terminal box, ensure that the top cover of the box is correctly installed prior to powering on the fan.
- A grounding check is mandatory before usage. The cross-sectional area of the ground wire must not be less than  $0.75\text{mm}^2$  (minimum 18AWG).

#### Risk of physical injury

- The system must have sufficient structural integrity to support the operation of the fan, and it is recommended to use screws equipped with anti-loosening mechanisms for fan installation. The distance between the fan and surrounding components should be no less than 25mm.
- Before conducting maintenance, it is crucial to deactivate the power and wait for the equipment to be completely stopped. Ensure the fan remains inactive throughout the maintenance period, and clear all materials after completion.
- Upon powering on, the fan may start operating immediately due to control voltage or stored speed settings. Therefore, please ensure that individuals and objects maintain a safe distance from the fan.
- If there is a risk of individuals coming into contact with the fan blades, it is strongly recommended to install a protective guard or cover. These protective measures must comply with relevant safety regulations.
- Exercise caution to prevent long hair or loose clothing from becoming entangled in the fan, potentially resulting in injury.
- Personnel are advised to wear appropriate gloves and footwear to minimize the risk of cuts and impacts.

#### Others risks

- The fan motor generates heat during operation, posing a potential burn risk to individuals. It is advisable to install a safeguard if necessary, and nearby components should be able to tolerate this heat.
- During fan operation, high decibel levels may be generated, posing a risk of hearing damage to operators. It is advisable to implement soundproofing or protective mechanisms to mitigate this risk.
- Please ensure that the entire setup adheres to EMC standards, and apply appropriate shielding to the system.

## Appendix : Storage / transportation / maintenance

### Storage and transportation

- Refer to the datasheet for the suitable ambient temperature range for storage, avoid storing in environments with long-term high relative humidity (higher than 60% RH); ensure that the storage environment is well-ventilated.
- It is recommended to store or transport using the original packaging and pallet. Ensure that the packaging remains intact, avoid any collisions or impacts.
- The total height of stacked pallets should not exceed 2.5 meters.
- Avoid storing the fan in environments containing corrosive gases and liquids
- Avoid storing the fan in areas exposed to direct sunlight or prone to vibration.
- If the fan is stored within a system, ensure the wiring cover and cable gland are installed properly. If the system is stored outdoor, the fan is better to be shielded.
- The fan may contain an electrolytic capacitor. It is recommended to power it on at least once every 12 months and run the fan for at least 60 minutes to prevent capacitor degradation.

### Regular Maintenance Inspection Items

Recommended Maintenance Inspection Interval : Every 6 Months

Inspection items	Inspections method
If conditions on-site permit inspection during system operation, assess for any abnormal noise or vibration. Inspectors should stand in a secure position and adhere to all safety regulations.	Visual inspection/ Related equipment
Check the ambient temperature and humidity surrounding the fan are within the range of specified.	Related equipment
Check the input voltage and control voltage are normal.	Related equipment
Inspect the vicinity of the fan for any foreign objects or potentially hazardous materials that could enter the fan's operational space and induce hazards.	Visual inspection
Inspect for any abnormal conditions in the vicinity of the fan, such as the presence of oil or water droplets, or any odors indicative of burning.	Visual inspection/ Odor inspection
Check if there is any dust or foreign objects obstructing the air intake and exhaust sides of the system	Visual inspection
Inspect for any fasteners or cables that may have loosened.	Visual inspection/ Torque confirmation
Inspect the fan body and cables for any indications of deformation, cracks, damage, aging, or discoloration.	Visual inspection
Inspect whether the fan body is covered with dust, as this may affect fan's heat dissipation.	Visual inspection

## Appendix : Installation Guide

### Fan installation

Before installation, please carefully read the **Safety Instructions**. If any anomalies are detected during the unpacking process, such as dents, cracks, or fragments, refrain from using the fan and promptly notify the Delta contact window for further assistance. Generally, there are two installation scenarios: one for installing a single fan and the other for installing a fan with a frame or bracket. Please refer to the following instructions for detailed guidance accordingly. During installation, avoid using the fan blades as lifting points.

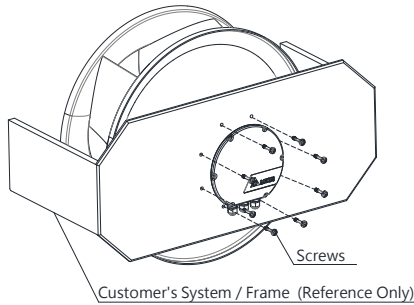

#### Single Fan

The fastening holes are primarily located behind the EC motor. The PCD (Pitch Circle Diameter), thread type, and thread depth can be referenced from the model specifications. If necessary, the cable gland may be removed during the installation process and then reattached once the fan is securely positioned. If the fan operates with a nozzle, please ensure proper concentric alignment and relative positioning. Recommended using Class 8.8 screws with torque values as listed below, and the engagement length  $>1.5d$  is suggested.

M5 52Kgf.cm / M6 90Kgf.cm  
M8 216Kgf.cm / M10 430Kgf.cm  
(Torque tolerance  $\pm 10\%$ )

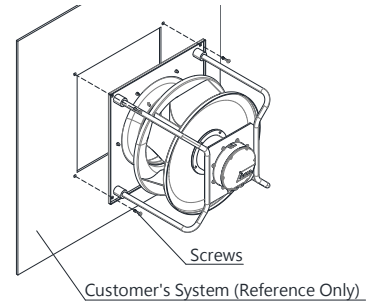

#### Fan with Frame/bracket

The fastening holes are primarily situated on the frame/bracket. The quantity, size, and positioning of installation holes may vary depending on the customer's specific installation system.

### Wiring cover installation (models with terminal box only)

Please adhere to the instructions provided below for the correct installation of the motor cover, as improper installation may result in water ingress and subsequent damage to the fan. Any damage incurred due to inadequate installation will not be covered under warranty. The appearance of the cover may vary among models. Nevertheless, the installation procedures and principles remain consistent.

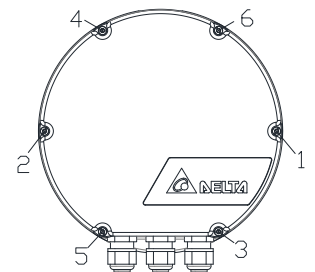

M4 Screw Torque  
1<sup>st</sup> round 10 Kgf.cm  
2<sup>nd</sup> round 17 Kgf.cm  
(Torque tolerance  $\pm 10\%$ )

#### Guideline & Steps :

When tightening the screws, it is crucial to do so in two stages with different torque settings. This ensures even stress distribution across the motor cover and helps prevent deformation.

##### STEP 1:

After properly positioning the motor cover, tighten the screws in a diagonal sequence (for example, in the order of 1, 2, 3... as illustrated above), following the first round torque values and order of tightening.

##### STEP 2:

Tighten the screws again in the same sequence according to the second round torque.

#### Notes:

Avoid tightening all screws directly to the target value, as this may compromise the fan's waterproofing.

Upon completion, please inspect the cover for any misalignment or gaps. Should any such issues be detected, please reinstall the cover. If the above problems persist or if any damage is observed, please promptly notify the Delta contact window for assistance.

In environments that may potentially exceed specifications, such as extended outdoor exposure to sunlight and rain, users should increase waterproofing measures, for example, applying supplementary sealant around the wiring cover.

## Appendix : Installation Guide

### Cable Gland Installation (models with cable gland only)

Please adhere to the instructions below for the proper installation of cable glands, as incorrect installation may result in water ingress and subsequent damage to the fan. Damages incurred due to improper installation will not be covered by the warranty. Delta EC fans feature various motor modules tailored for different applications, each employing different cable gland types or combinations. Please identify the appropriate cable gland type for cable wiring and installation guidelines.

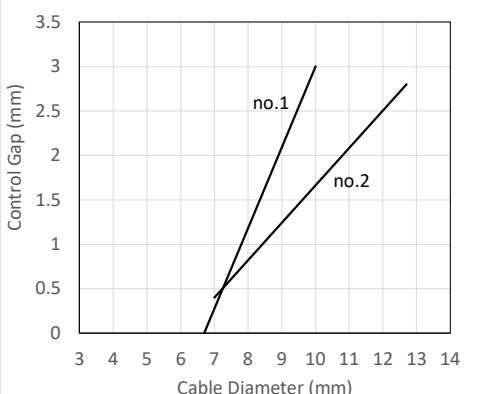
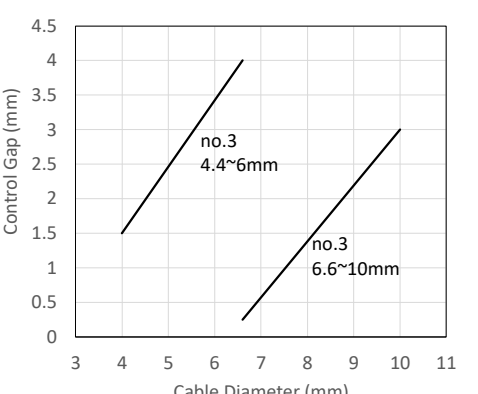
Information of Cable Gland			
No	No.1	No.2	No.3
Type	M16 X 1.5 Single layer rubber	M20 X 1.5 Single layer rubber	M16 X 1.5 Double layer rubber
Cable Dia.	6.6~10.0 mm	7~12.7 mm	Using 1 layer : 6.6~10.2 mm Using 2 layers : 4.6~6.6 mm
Gland Body-Fan Suggested Toque	26 Kgf.cm±10%	40 Kgf.cm±10%	26 Kgf.cm±10%
Control Gap (mm)			

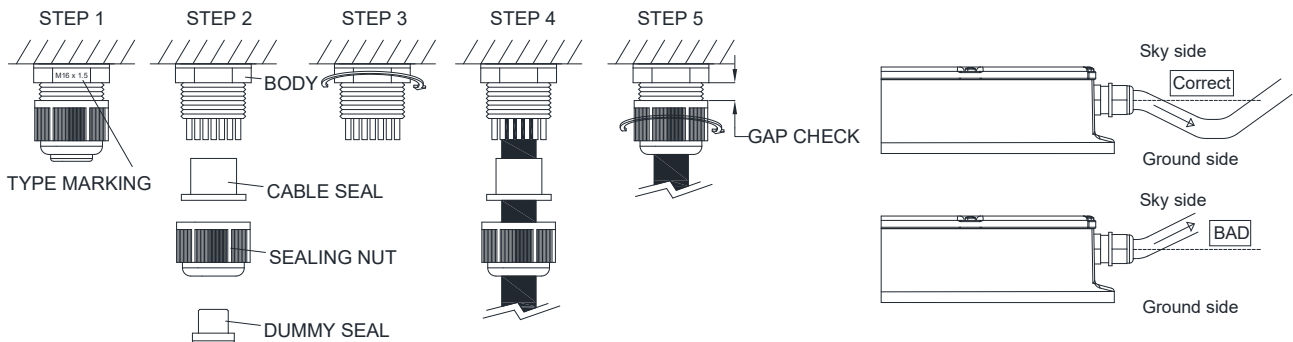

#### Installation Step

1. Identify the specification of the cable gland. (refers to preceding Table)
2. Loosen the sealing nut.
3. Tighten the body; please consult preceding table for the recommended torque. (Repeat STEPs 1-3 for other cable glands.)
4. Route the cables sequentially through the sealing nut, cable seal, and cable gland body into the motor terminal box for wiring.
5. After wiring, securely tighten the sealing nut and fasten the cables. Utilize the "Control Gap" method to verify proper cable installation. The "Control Gap" corresponds to the cable diameter, and the gap measurement should be slightly less than the specified value.

#### Notes :

1. Ensure that the cable diameter aligns with the recommended specifications, allowing only one cable to pass through each cable gland. Verify that all torques and control gap measurements adhere to the suggested values.
2. Retain all dummy seals if certain cable glands are unused, ensuring that all torques and control gap measurements meet the prescribed values provided.
3. Position cables to face downwards to prevent water ingress into the fan motor; avoid orienting cables upwards.
4. Proceed with motor cover installation only after ensuring proper installation of all cable glands.