



## Specification For Approval

CUSTOMER : STD  
DESCRIPTION : 1000W 180-240VAC 50/60Hz Heater  
CUSTOMER PART NO. : \_\_\_\_\_ REV. : \_\_\_\_\_  
DELTA MODEL NO. : HEH100BA REV. : 10  
SAMPLE ISSUE NO. : \_\_\_\_\_  
SAMPLE ISSUE DATE : Dec.26 2018

Please send one copy of this specification back after you signed approval for production pre-arrangement

Approved by : \_\_\_\_\_

Date : \_\_\_\_\_  
\_\_\_\_\_

DELTA ELECTRONICS, INC.  
252, SHANG YING ROAD, KUEI SAN  
TAOYUAN HSIEN 333, TAIWAN, R. O. C.

TEL : 886-(0)3-3591968  
FAX : 886-(0)3-3591991

\*\*\* SAMPLE HISTORY\*\*\*

CUSTOMER: \_\_STD\_\_

CUSTOMER P/N:

DELTA MODEL : HEH100BA

REV.	DESCRIPTION	DRAWN	CHECKED			APPROVED	ISSUE DATE
			ME	EE	CE		
0	Issue spec.	李武奇 4/27'12	李武奇 4/27'12	涂雅森 4/27'12	-----	陳英琦 4/27'12	4/27'12
1	Modify outside dimension & Function description	李武奇 9/03'12	李武奇 9/03'12	涂雅森 9/03'12	----	陳英琦 9/03'12	9/03'12
2	Add earth mark on 1-3-1 drawing,Delete External sensor connector & Correct Alarm contact rating on 2-1.	李武奇 11/01'13	李武奇 11/01'13	涂雅森 11/01'13	----	陳英琦 11/01'13	11/04'13
3	Add CUL certificate number on 5-1	李武奇 05/08'14	李武奇 05/08'14	涂雅森 05/08'14	----	陳英琦 05/08'14	05/08'14
4	Add Defination of MTBF and Protection rating	王慶順 08/13'15	王慶順 08/13'15	涂雅森 08/13'15	----	陳英琦 08/13'15	08/17'15
5	Modify the operating voltage to wide range	李武奇 09/03'15	李武奇 09/03'15	涂雅森 09/03'15	----	陳英琦 09/03'15	09/03'15
6	Modify the operating voltage range	李武奇 09/18'15	李武奇 09/18'15	涂雅森 09/18'15	----	陳英琦 09/18'15	09/18'15
7	Add warranty description	李武奇 05/06'16	李武奇 05/06'16	賴世育 05/06'16	----	楊家瑋 05/06'16	05/06'16
8	Modify section 1-2 inrush current to start current.	李明遠 12/23'16	李明遠 12/23'16	賴世育 12/23'16	-----	楊家瑋12/23'16	12/23'16
9	Section 1-2 & section 4 adding description	李武奇 1/17'18	李武奇 1/17'18	涂雅森 1/17'18	-----	陳加偉 1/17'18	1/18'18
10	correction 2-1&3-1 description,Add Section.7 package.	李武奇 12/26'18	李武奇 12/26'18	涂雅森 12/26'18	----	陳加偉 12/26'18	12/26'18

## Table of contents

1. Description .....	2
1-1 General description : .....	2
1-2 Main feature & model number .....	2
1-3 Dimension .....	3
1-4 Configuration & Maintenance .....	5
1-5. Thermal path & airflow baffle .....	6
2. Electrical specifications.....	7
2-1. Indicators & connector.....	7
2-2. AC power supply .....	8
2-3. Control mode.....	9
2-4. Over Heat Protection .....	9
3. Environmental conditions.....	9
3-1. Operating temperature : .....	9
3-2. Storage temperature :.....	9
3-3. Humidity.....	9
3-4. Protection rating .....	9
3-5. MTBF.....	9
4. Reliability table.....	9
5. Certified safety.....	10
6. Package and Assembly .....	10
6-1 Package .....	10
7. Delta Electronics, Inc. Warranty for Cabinet Thermal Solutions Products .....	10

Specification for approval

Customer : STD

Description : 1000W 180-240VAC 50/60Hz Heater

Customer p/n :

rev. :

Delta model no. : HEH100BA

rev. : 10

Sample rev.:

issue no. :

Sample issue date :

quantity : sets

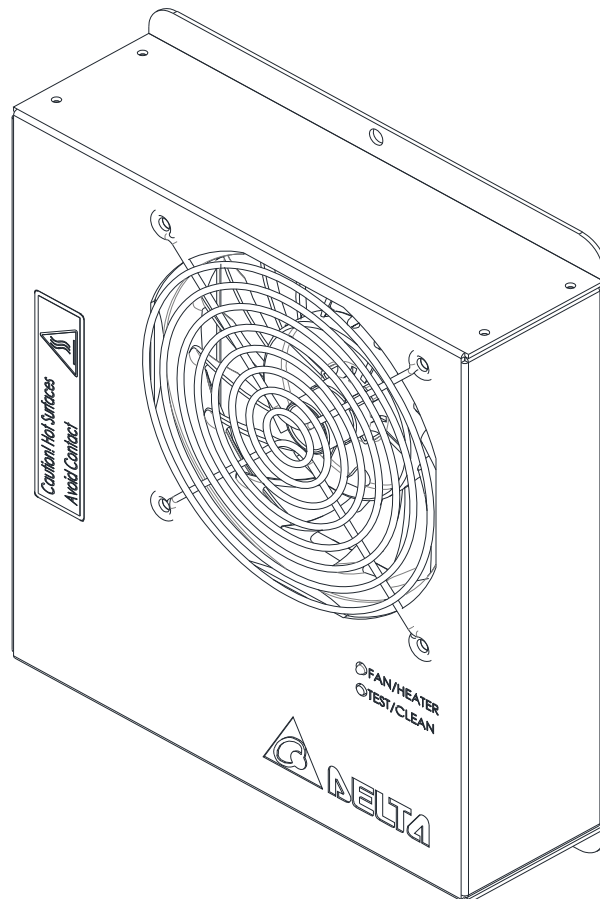

PART NO :

DELTA HEATER MODEL : HEH100BA

## 1. Description

### 1-1 General description :

The heater is designed for warming up air in the cabinet. It heats air to avoid equipment damaged from over-cool air. The heater can be mounted on the wall of cabinet.

### 1-2 Main feature & model number

Main feature	Unit	Model number
		HEH100BA
Outline dimensions	mm	235 H x 185 W x 58 D
Weight	kg	1.5 ± 0.5
Warming capacity	W	1000 ±10% @20°C
Airflow rate	CFM	67(TYP)
Rated voltage	Vac	220. (TYP.)
Operating voltage range	Vac	180-240
Current (continuous)	A	5 @240 Vac
		6.8 @ 220 Vac -40°C (Max.)
Controller		Built-in
Operating status		LED indicator
Fan /Heater fail alarm		Dry contact output
Acoustic noise at 1M : (Sound pressure)	dB-A	65.0 (typ.)
Start current *Note 3	A	12 @ 220 Vac -40°C (max)
Mounting location		Internal wall

\*Note 1: The heating capacity (W) is defined as power consumption.

\*Note 2: The variation of current is depended on ambient temperature.

\*Note 3: The start current is at the time while PTC heating on. The current peak time less than 5sec.

PART NO :

DELTA HEATER MODEL : HEH100BA

### 1-3 Dimension

#### 1-3-1 Drawing

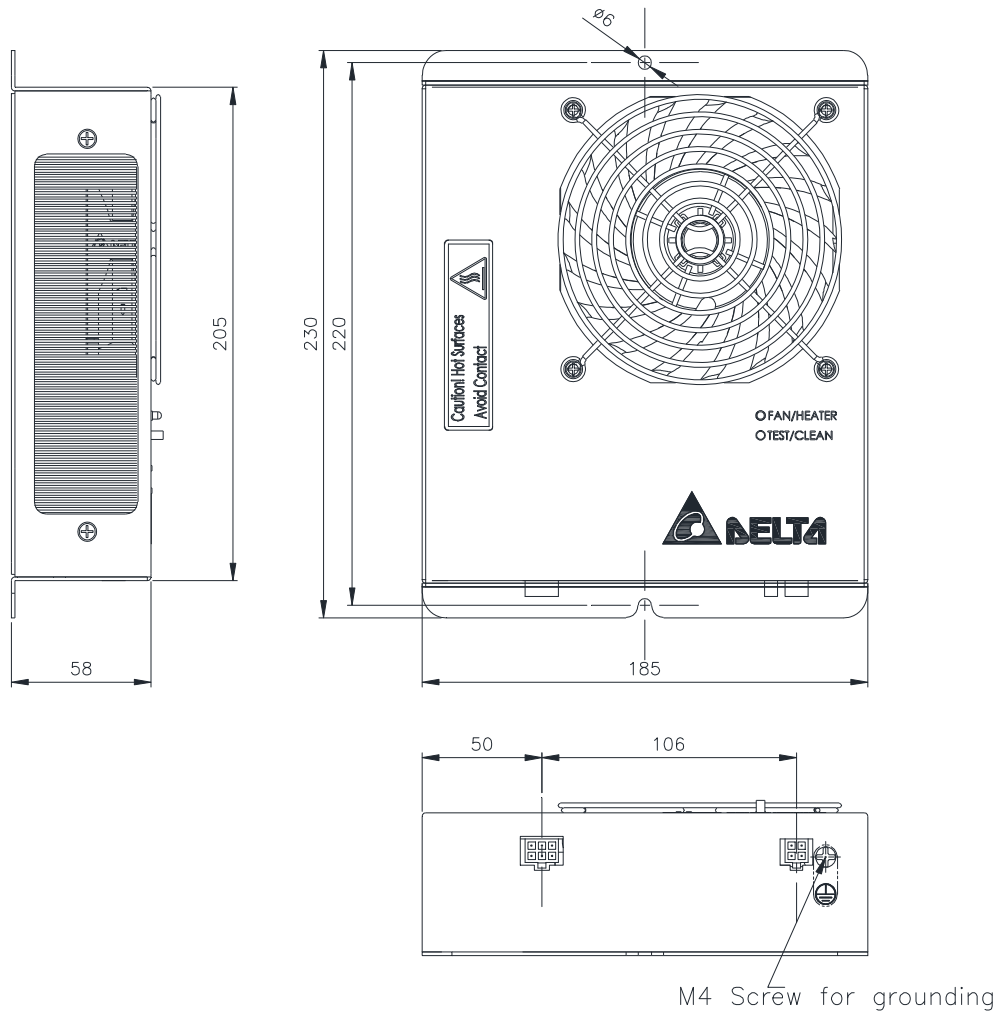

(1) Material: case aluminum sheet

(2) Finish: RAL 7032

(3) Dimensional tolerance:

Decimal

X :  $\pm 1$  mm

X.X :  $\pm 0.3$  mm

PART NO :

DELTA HEATER MODEL : HEH100BA

**1-3-2 Mounting type**

Wall mount

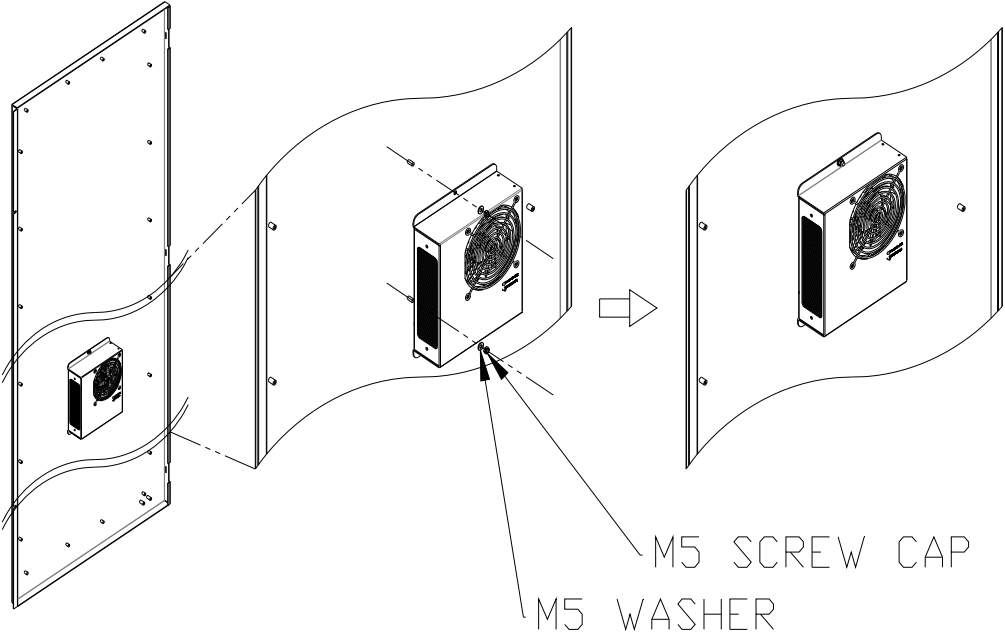
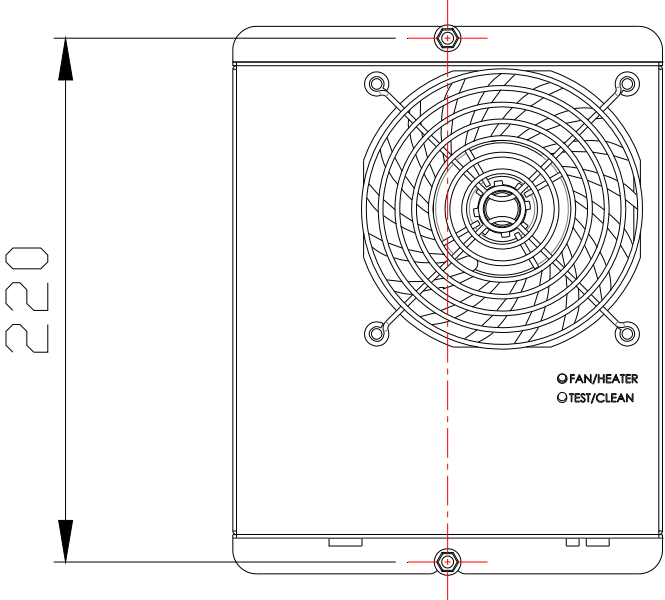

PART NO :

DELTA HEATER MODEL : HEH100BA

### 1-4 Configuration & Maintenance

HEH100BA is designed to be maintained easily inside cabinet. Take off the back cover, and then it is easy to replace the fan, PTC Heater and control board.

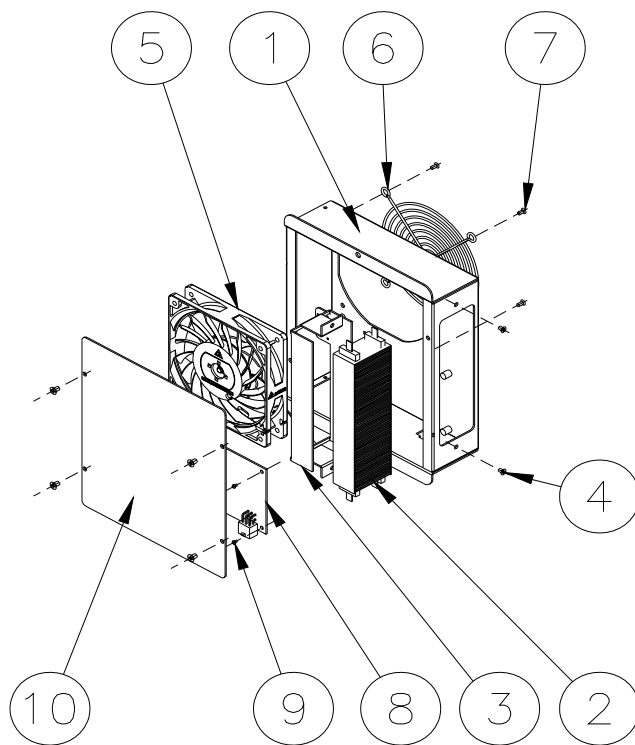

NO.	Q'TY	Description
1	1	Case
2	1	Heater
3	1	Bracket
4	6	Mount screw(M4)
5	1	DC fan
6	1	Fan guard
7	4	Mount screw
8	1	Control board
9	7	Mount screw (M3)
10	1	Back cover



PART NO :

DELTA HEATER MODEL : HEH100BA

### 1-5. Thermal path & airflow baffle

The air flow is pumped by DC fan inside the heater. The cool and warm air flow passages are shown below. Cool air is heated by PTC then supplied to the system.

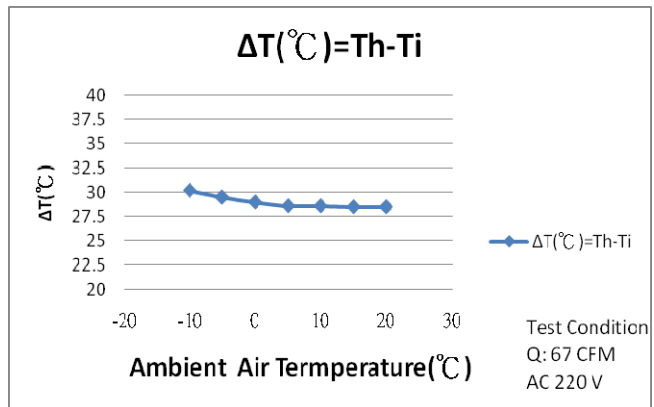
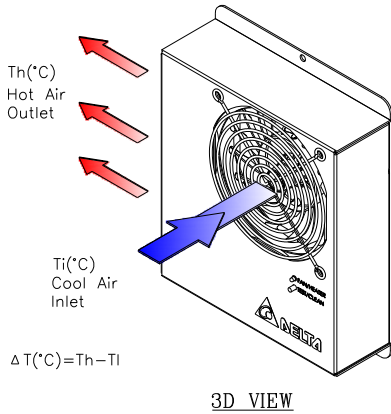

\*Note A. Minimum gap is required on inlet and exit passage to avoid trigger the protection of thermostat or fuse

\*Note B. Do not downward the supply air to avoid short circulation

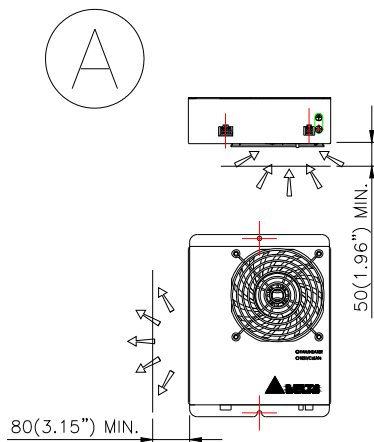

\*Do not allow hot air flow downward!

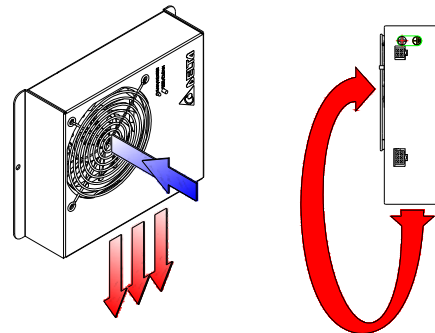

PART NO :

DELTA HEATER MODEL : HEH100BA

## 2. Electrical specifications

### 2-1. Indicators & connector

The HEH100BA has an interface to back plane and it can be connected and disconnected flexibly. The interface is composed of power connectors, signal connector, and alarm output.

\*Disconnect power to device before inserting or removing connector.

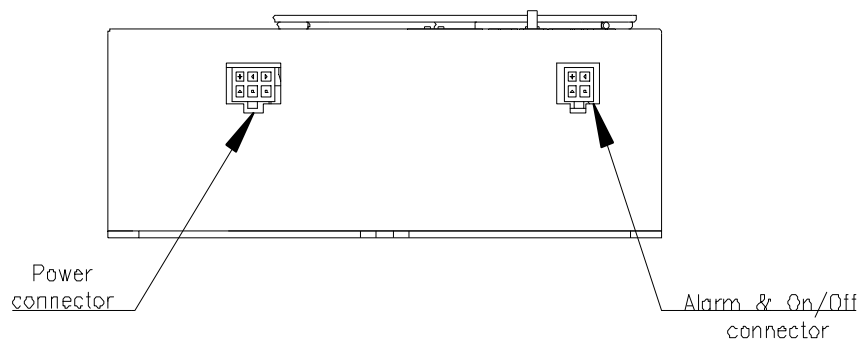

JWT P/N C4201WR0-6PNL

Mate with JWT C4202H00-2\*3P or Equivalent.

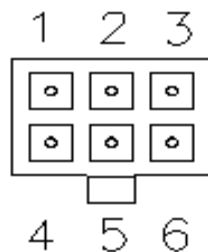

Power connector	
Pin	Function
1	L(AC 220V )
2	
3	N(AC 220V )
4	L(AC 220V )
5	
6	N(AC 220V )

Signal connector: JWT P/N C4201WR0-4PNL

Mate with JWT C4202H00-2\*2P or Equivalent.

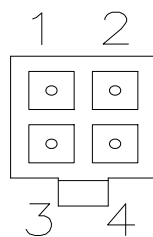

Power connector	
Pin	Function
1	Alarm contact
2	ON/OFF control
3	Alarm contact
4	ON/OFF control

Alarm logic ( N.C )

PART NO :

DELTA HEATER MODEL : HEH100BA

- Fan & Heater normal:  
Pin 1 and pin 3 dry contact close
- FAN or Heater Failed:  
Pin 1 and pin 3 dry contact open
- Internal sensor failed  
Pin 1 and pin 3 dry contact open
- Over heating (case part above 50 °C)  
Pin 1 and pin 3 dry contact open  
Alarm contact ----- Max. ( ± 60VDC ,100mA)

#### Switch "TEST"

Press the "TEST/CLEAN" button, LED will blink and HEH100BA will run heat function automatically about two minutes. It can be off by pressing the test button again.

- LED "FAN/HEATER"  
(Dark) : Heater off  
(Green) : Heater on  
(Red) : Fan ,heater or over heating failed  
(Blink Green) : Fan normal in test process  
(Blink Red) : Failed in test process or sensor failed

○ FAN/HEATER

○ TEST/CLEAN

## 2-2. AC power supply

HEH100BA is designed for AC 220V power supply in accordance with the following parameters: Input Voltage Range: AC 180-240V

Nominal Voltage: AC 220V

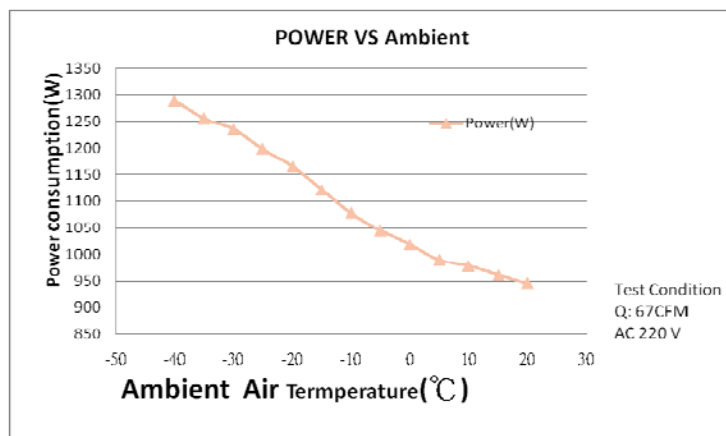

PART NO :

DELTA HEATER MODEL : HEH100BA

### 2-3. Control mode

User can control HEH100BA heat function by ON/OFF control pin2 & pin4 open or close.

	ON/OFF control pin 2 & 4	HEH100BA
Switch module control	CLOSE (<100ohm)	Heater function ON
	OPEN (>100Kohm)	Heater function OFF

User is able to connect to a switch to control HEH100BA work status without electric input.

### 2-4. Over Heat Protection

HEH100BA has internal sensor to detect temperature. When temperature on the heater surface is over 50 °C, the power will be off by controller. If the fan is locked or internal sensor failed, HEH100BA will also be turned off immediately, and LED will indicate the HEH100BA status.

## 3. Environmental conditions

### 3-1. Operating temperature :

-40°C ~ +65°C (-40°F ~ 149°F)

### 3-2. Storage temperature :

-40°C ~ +75°C (-40°F ~ 167°F)

### 3-3. Humidity

5 ~ 90% RH, Non-condensing

### 3-4. Protection rating

IP20 (IEC60529)

### 3-5. MTBF

The L10 Fan life is expected at least 80,000 hours continuously operates at 40°C with 15 ~ 65%RH @ label rated voltage.

## 4. Reliability table

Test item	Condition
High temp	IEC 60068-2-2
Low temp	IEC 60068-2-1
Temperature cycle	IEC 60068-2-3
Vibration	ETSI 300 019-1-4 CLASS 4.1
Package bump	IEC 60068-2-29
Hi-pot	L&N to case 1500Vac,1s,<100mA

PART NO :

DELTA HEATER MODEL : HEH100BA

## 5. Certified safety



## 6. Package and Assembly

### 6-1 Package

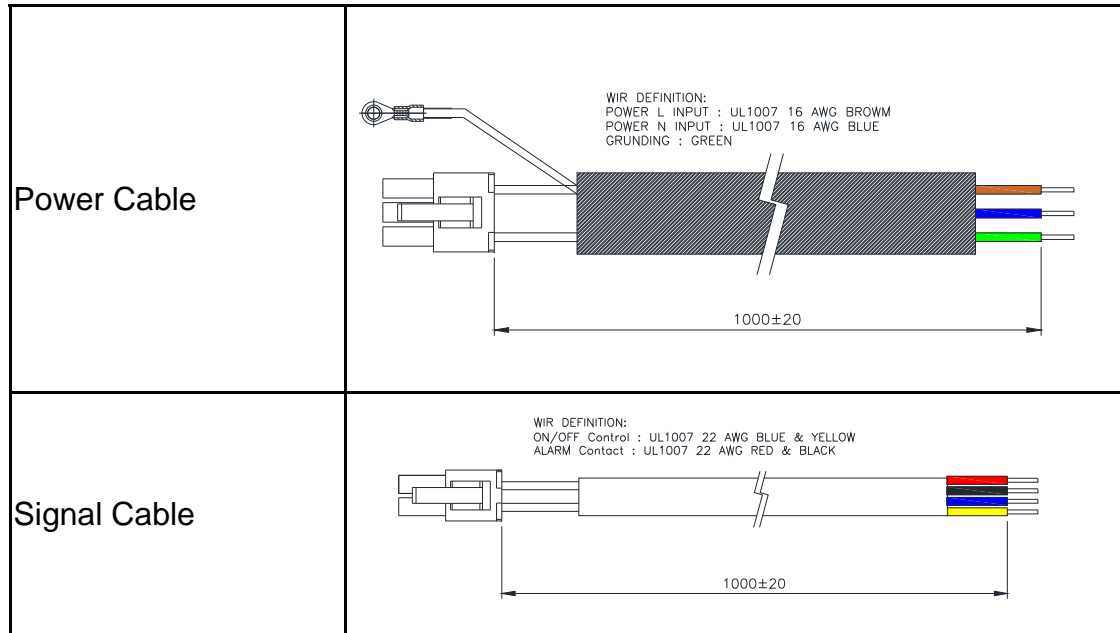

## 7. Delta Electronics, Inc. Warranty for Cabinet Thermal Solutions Products

Delta Electronics, Inc warrants that HEATER and accessories within its Cabinet Thermal Solutions product family and manufactured by Delta Electronics, Inc., herein referred to as (“products”), will be free from defects in material and workmanship for a period of one (1) year from the date of shipment by Delta Electronics, Inc. This warranty covers repair or replacement of product at the sole discretion of Delta Electronics, Inc. and is subject to the following Conditions and Exclusions:

### A. Conditions.

- All products must be installed and operated according to Delta product Specification(s) and product Instruction/User Manual(s):

PART NO :

-----  
DELTA HEATER MODEL : HEH100BA  
-----

- Maximum voltage variation is no greater than normal operation and instruction in Delta product Specification(s) and product Instruction/User Manual(s), with avoidance to power line disturbances of any kind.
- Application is not to exceed minimum and maximum stated operation temperatures and humidity range as indicated in the Delta product Specification(s) and product Instruction/User Manual(s).
- Filters (if applicable) must be cleaned regularly.
- Products and any parts thereof must not be modified, unless prior written authorization is received from Delta Electronics, Inc.
- All products must be installed and grounded in accordance with all relevant electrical and safety codes, as well as the National Electric Code and OSHA rules and regulations.
- All products must be installed in a stationery application, free of vibration and shock.
- A violation of any one of these conditions shall render the warranty hereunder void and of no effect.

#### **B. Exclusions.**

This warranty does not cover the following:

- Applications where products are being misapplied. This includes inappropriate selection of products for the environment and conditions in which it is to be used.
- Damages caused by shipping carrier or any other accident after products have left Delta Electronics, Inc. manufacturing facility. Shipping claims are the responsibility of the customer and are to be completed in a timely manner.
- Reimbursement of labor for installation or removal of any warranted products, or for parts and labor resulting from repairs performed by any other source besides Delta Electronics, Inc.

This is the complete warranty and is in lieu of any other warranty expressed or implied, including but not limited to any implied warranty of merchantability or fitness for a particular purpose. Delta Electronics, Inc. will in no way be liable for incidental or consequential damage whatsoever or for any other claims by

PART NO :

-----  
DELTA HEATER MODEL : HEH100BA  
-----

the customer for damages in connection with Delta Electronics Inc. products, even if advised in advance of the possibility of such damage.

### **Return Procedure**

All returns require a Return Material Authorization number (RMA #), regardless of reason for return, whether it be for warranty or out of warranty repair. Returns without an RMA # will be refused by Delta Electronics, Inc. Approval for return requests are at the sole discretion of Delta Electronics, Inc.

Buyer should provide the following information at the time of RMA request:

1. Complete Model Number, Serial Number and description of damaged unit requested to be returned.
2. Original Buyer Purchase Order number and date product was received by Buyer.
3. Quantity to be returned and a brief description of failure for each unit, if different.

All returns to Delta Electronics, Inc must be securely packed, using original cartons if possible. All returns must have the RMA number visible on the outside of the carton. Delta Electronics, Inc. is not responsible for material damaged in transit.

Shipping cost for all non-warranty repairs is the responsibility of the sender and must be shipped prepaid. Shipping costs for all warranty related repairs will be covered by Delta Electronics, Inc. provided the products are returned using a Delta Electronics, Inc approved carrier. If after diagnosis, products determined by Delta Electronics, Inc. are not covered under warranty, Buyer will be responsible for all shipping charges and will be billed accordingly.

### **LIMITATION OF LIABILITY**

DELTA ELECTRONICS, INC. WILL NOT BE LIABLE UNDER ANY CIRCUMSTANCES FOR ANY INCIDENTAL, CONSEQUENTIAL OR SPECIAL DAMAGES, INCLUDING WITHOUT LIMITATION ANY LOST PROFITS OR LABOR COSTS, ARISING FROM THE SALE, USE OR INSTALLATION OF THE GOODS, FROM THE PRODUCTS BEING INCORPORATED INTO OR BECOMING A COMPONENT OF ANOTHER PRODUCT, FROM ANY BREACH

PART NO :

-----  
DELTA HEATER MODEL : HEH100BA  
-----

OF THIS AGREEMENT OR FROM ANY OTHER CAUSE WHATSOEVER, WHETHER BASED ON WARRANTY (EXPRESSED OR IMPLIED) OR OTHERWISE BASED ON CONTRACT, OR ON TORT OR OTHER THEORY OF LIABILITY, AND REGARDLESS OF ANY ADVICE OR REPRESENTATIONS THAT MAY HAVE BEEN RENDERED BY DELTA ELECTRONICS, INC. CONCERNING THE SALE, USE OR INSTALLATION OF THE PRODUCTS.