



## Specification For Approval

Customer : \_\_\_\_\_  
Description : Thermoelectric cooler 200W  
Customer part no : \_\_\_\_\_ Rev. : \_\_\_\_\_  
Delta model no : HET200PC-B Rev. : 04  
Sample issue no : \_\_\_\_\_  
Sample issue date : Mar.30.2016

### Modify history

Rev.	Description	Drawn	Approved	Issue Date
00	ISSUE SPEC .	Nick Wang	Ken Chou	2013/10/22
01	Add the grounding feature on case	Nick Wang	Ken Chou	2013/11/20
02	Update the grounding area	Nick Wang	Ken Chou	2013/11/25
03	Modify the airflow & Certified safety	Nick Wang	Ken Chou	2014/04/22
04	Add chapter 6 warranty & correct some data	Derek JH Tsai	Jerry Yang	2016/3/30

Please send one copy of this specification back after you signed approval for production pre-arrangement

Approved by : \_\_\_\_\_

Date : \_\_\_\_\_

DELTA ELECTRONICS, INC.  
252, SHANG YING ROAD, KUEI SAN  
TAOYUAN HSIEN 333, TAIWAN, R. O. C.

TEL : 886-(03)-3591968  
FAX : 886-(03)-3591991



## Table of content

<b>1. Description .....</b>	<b>4</b>
<b>1-1. General description :.....</b>	<b>4</b>
<b>1-2. Main feature (Operating 48VDC at 25 ° C) .....</b>	<b>4</b>
<b>1-3. Dimension .....</b>	<b>5</b>
<b>1-3-1 Drawing .....</b>	<b>5</b>
<b>1-3-2 Mounting panel cutout .....</b>	<b>6</b>
<b>1-4. Maintenance .....</b>	<b>7</b>
<b>1-5. Thermal path and airflow baffle .....</b>	<b>8</b>
<b>2. Electrical specification .....</b>	<b>9</b>
<b>2-1. Indicator &amp; connector .....</b>	<b>9</b>
<b>2-2. Cooling Performance VS Temperature Difference.....</b>	<b>9</b>
<b>2-3. TEC work temperature range.....</b>	<b>9</b>
<b>2-4. Interface .....</b>	<b>10</b>
<b>3. Environmental conditions .....</b>	<b>12</b>
<b>3-1. Operating temperature: .....</b>	<b>12</b>
<b>3-2. Storage temperature: .....</b>	<b>12</b>
<b>3-3. Humidity .....</b>	<b>12</b>
<b>3-4. Protection rating.....</b>	<b>12</b>
<b>3-5. MTBF .....</b>	<b>12</b>
<b>4. Certified safety .....</b>	<b>12</b>
<b>4-1. UL , CUL, CE , TUV.....</b>	<b>12</b>
<b>5. User cable .....</b>	<b>12</b>
<b>5-1 Power cable .....</b>	<b>12</b>
<b>6. Warranty .....</b>	<b>13</b>

## Specification for approval

Customer :

Description : Thermoelectric cooler 200W

Customer P/N :

Rev. :

Delta model no. : HET200PC-B

Rev. : 04

Sample revision :

Issue no. :

Sample issue date :

Quantity : sets

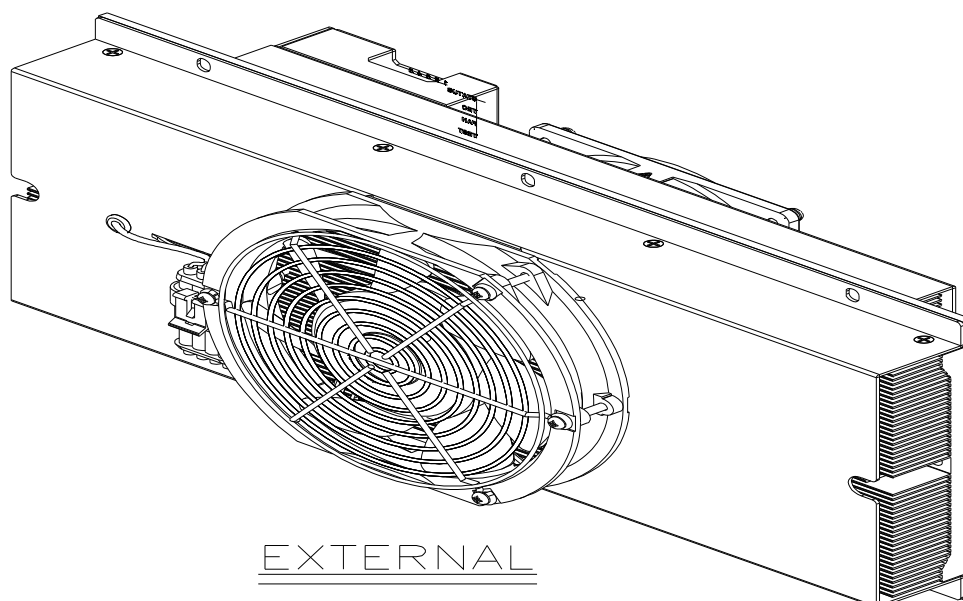
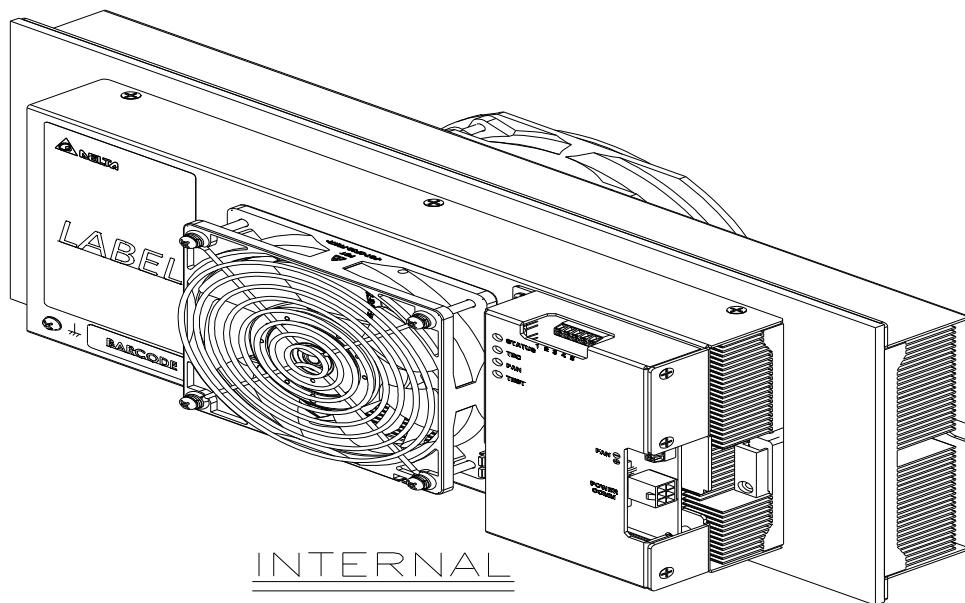

Part no. :

Delta model no. : HET200PC-B

## 1. Description

### 1-1. General description :

The Thermoelectric cooler (TEC) is designed for direct air to air heat removal in the cabinet. It is easy to be installed in the cabinet (recommended on the door of the cabinet) with the nuts.

The internal and external air circulation loops of the TEC Module are separated to prevent the entry of dust, humidity and dirt. The unit conforms to IP55 protection rating on the external air circuit.

### 1-2. Main feature (Operating 48VDC at 25 ° C)

Main feature	Unit	Model Number
		HET200PC-B
Outline dimension	mm	400 H x 181 W x 143 D
Weight	Kg	6.0± 0.5
Cooling capacity ( $\Delta T = 0$ °C)	W	200
Heating capacity @-40 ° C	W	225
Rated voltage	VDC	48 (TYP.)
Operating voltage range	VDC	40~56
Actually Current	A	6.1 (TYP.)
Rated Current	A	7.4 (MAX)
Rated Consumption	W	356(Max)
Operating temperature	°C	-40~55
Internal airflow rate	CFM	85 (TYP.)
External airflow rate		135 (TYP.)
Acoustic noise at 1M : (Sound pressure)	dB-A	65.0 dB-A(Typ). 69.0(max.)

Cooling and heating capacity is for internal side.

Part no. :

Delta model no. : HET200PC-B

### 1-3. Dimension

#### 1-3-1 Drawing

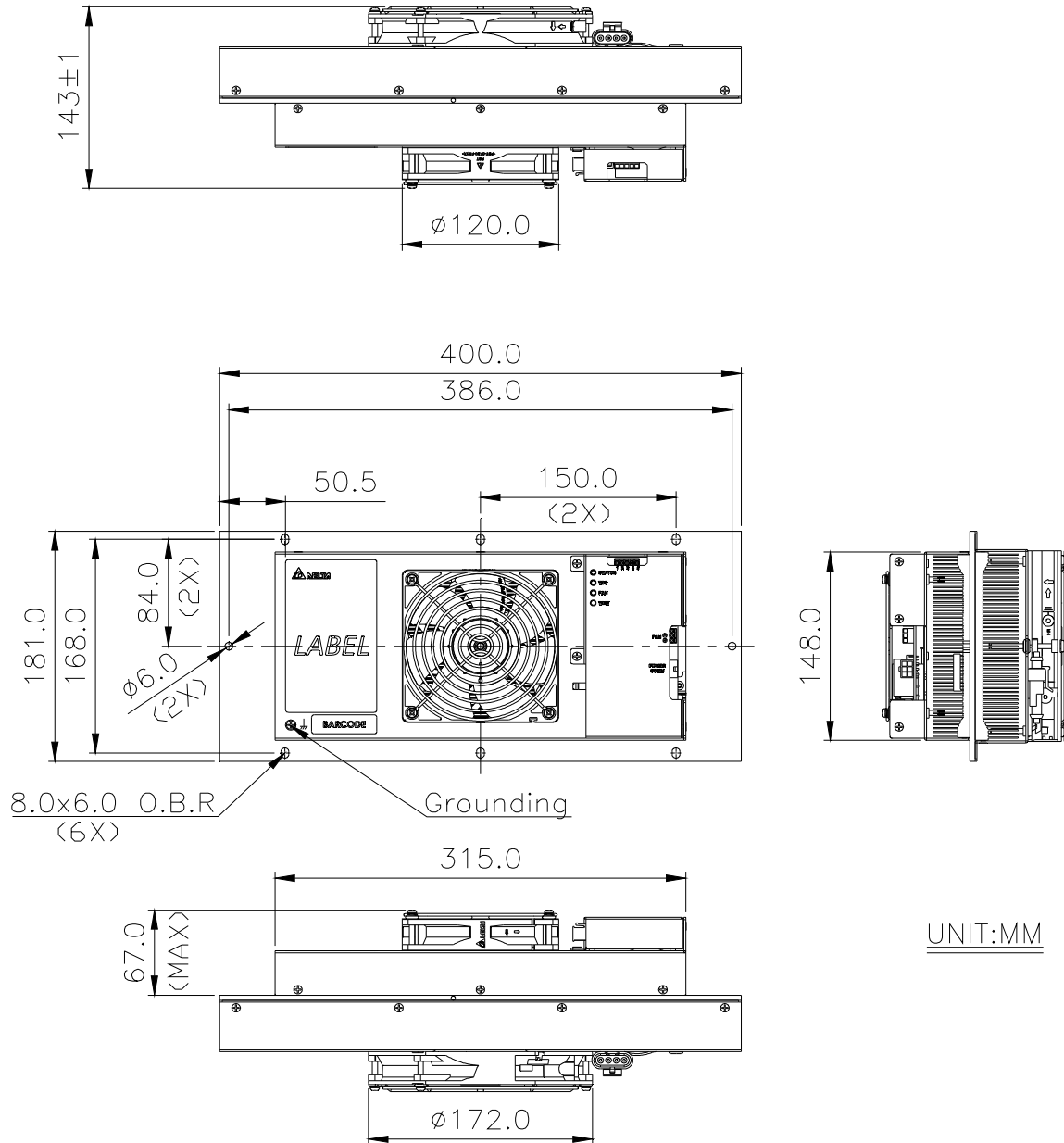

UNIT:MM

- (1) Material : case aluminum sheet , t=1.5mm
- (2) Finish : Power paint 75~120um,
- (3) Color : RAL 7032
- (4) Dimension tolerance:
  - X.X [X.XX] :  $\pm 1.0\text{mm}$  [0.04"]
  - X.XX [X.XXX] :  $\pm 0.3\text{mm}$  [0.012"]

Part no. :

Delta model no. : HET200PC-B

### 1-3-2 Mounting panel cutout

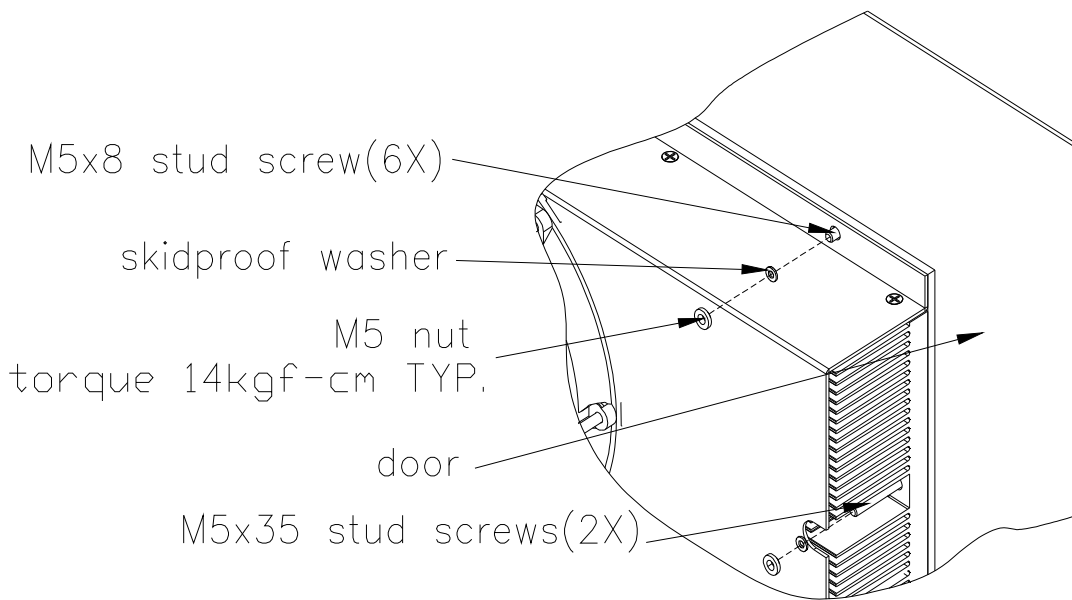
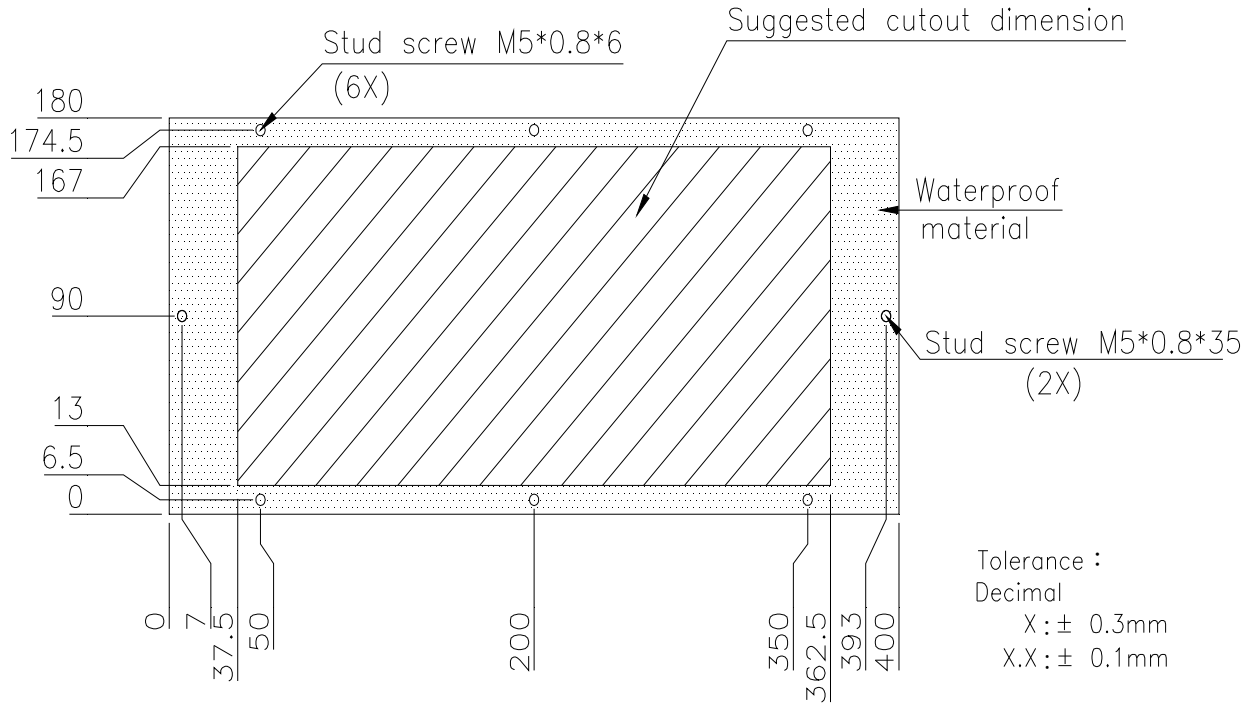

Part no. :

-----  
Delta model no. : HET200PC-B  
-----

#### **1-4. Maintenance**

- 1-4-1. Be sure to disconnect power supply before disassembly TEC module from customer cabinet.
  
- 1-4-2. Please refer to Delta authorized engineers for TEC module component replacement service, no allow unauthorized personnel to repair the unit.
  
- 1-4-3. If the replacement by user himself is necessary, please refer to the exploded drawing shown as previous page and below description for disassembly.

External fan: Disassemble mounting screw of external fan via screw driver & pull out the connector.

Internal fan: Disassemble mounting screw of internal fan via screw Driver & pull out the connector.

Controller: Need to disassemble internal fan first , then pull-out all cable connection on controller , take off mounting screw of controller finally .

TEC device: Due to TEC device have waterproof sealant protection and thermal conductive compound with heat-sink, please kindly ship back to Delta for replacement.



Part no. :

Delta model no. : HET200PC-B

### 1-5. Thermal path and airflow baffle

The thermal exchange path is shown in the figure below.

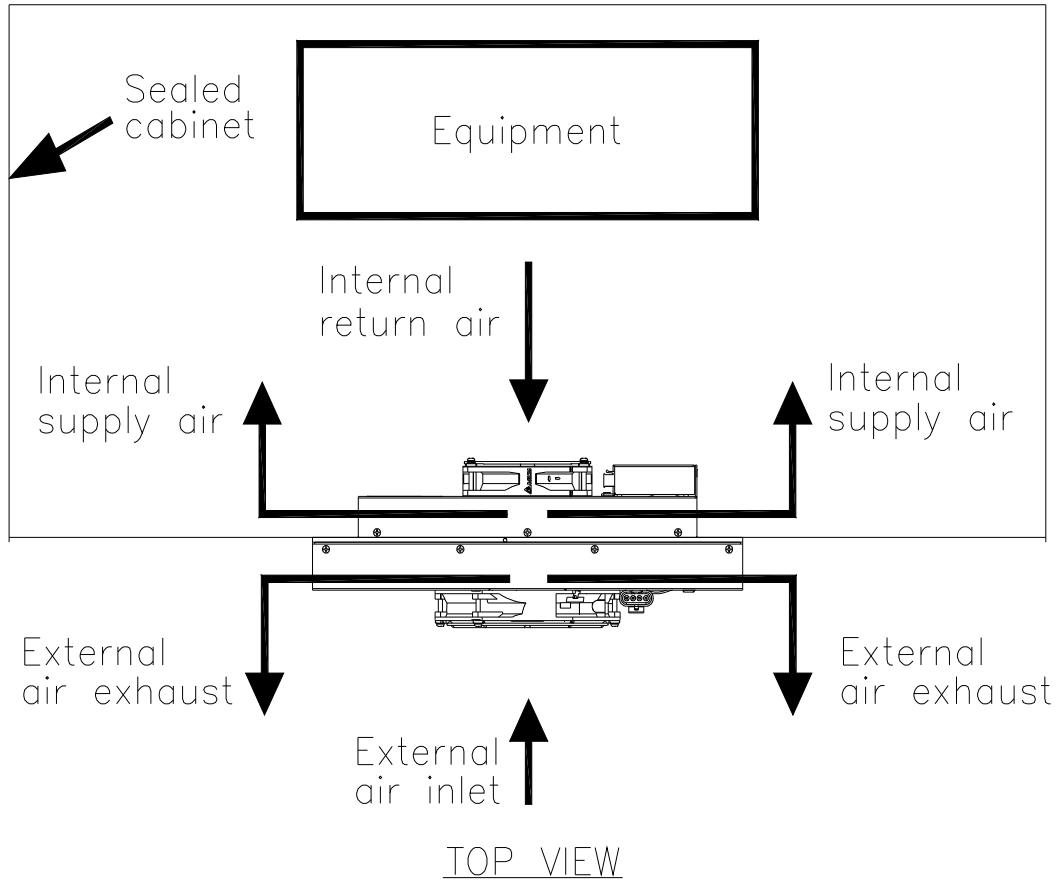

Part no. :

Delta model no. : HET200PC-B

## 2. Electrical specification

### 2-1. Indicator & connector

Connector " -48V VDC " mate with JWT C4201WR0-2\*3PNL

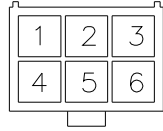

PIN	Function	PIN	Function
1	-48V (-)	4	-48V (-)
2	NA	5	NA
3	0V (+)	6	0V (+)

### 2-2. Cooling Performance VS Temperature Difference

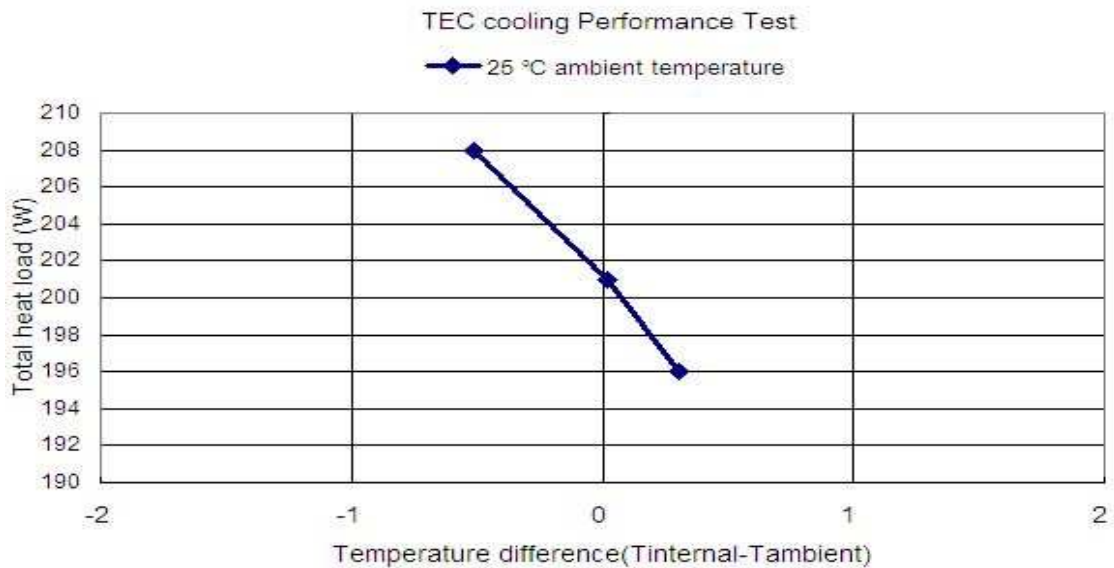

### 2-3. TEC work temperature range

HET200PC-B has two work status, cooling and heating, according to the cabinet internal temperature (detect by on-board NTC).

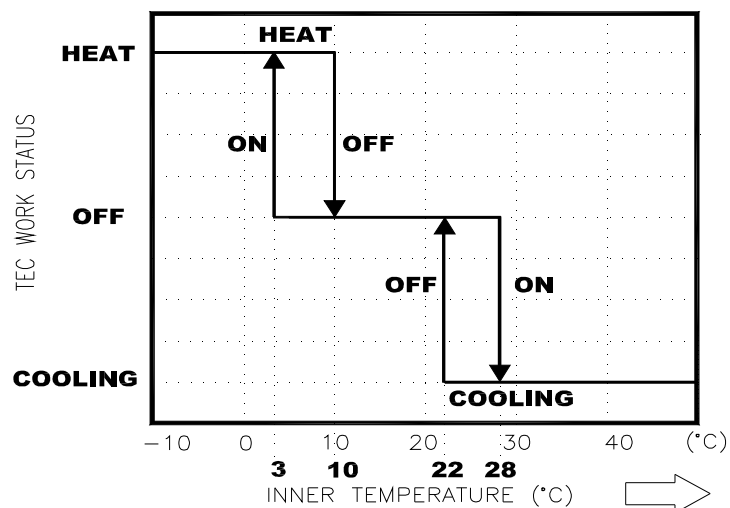

Part no. :

Delta model no. : HET200PC-B

## 2-4. Interface

HET200PC-B control-board interface is as diagram. The function will be described as following:

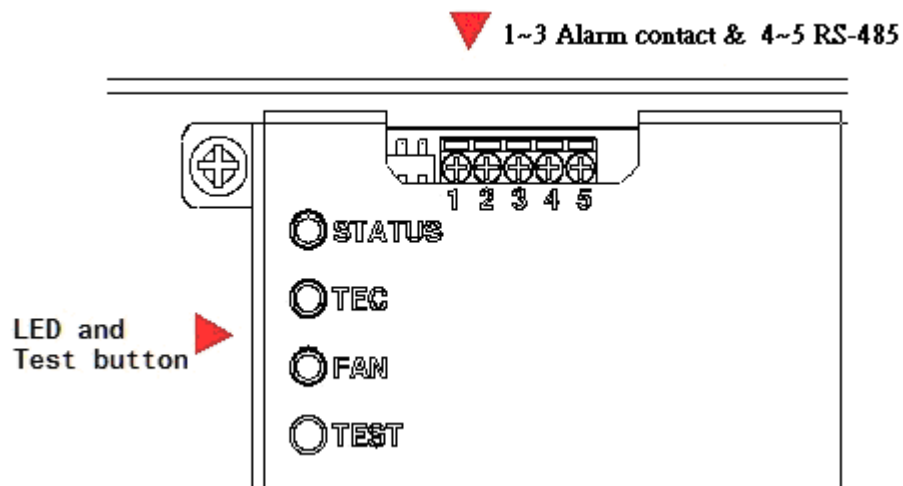

- LED "FAN"
  - (Green) : Fan normal
  - (Red) : Fan failed
  - (Blink Green) : Fan normal in test process
  - (Blink Red) : Fan failed in test process
- LED "TEC"
  - (Green) : TEC normal
  - (Red) : TEC failed
- LED "STATUS"
  - (Green) : HET200PC-B work in cooling mode
  - (Red) : HET200PC-B work in heating mode
  - (Dark): HET200PC-B TEC function OFF
  - (Blink Red): Temperature sensor fail
- CLEAN/TEST
  - There is an auto test button on HET200PC-B, user can press this button to run TEC module heating and cooling process, the process is about 3~4 minutes. User can turn off this function by pressing this button again.

Part no. :

Delta model no. : HET200PC-B

Alarm contact:

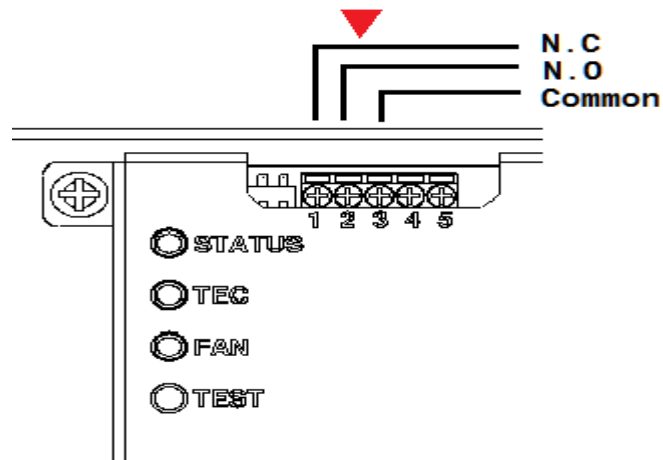

Alarm dry contact: (MAX. 60VDC 400mA or 125VAC, 400mA)

- Pin1 to pin3 “Close”:  
Normal
- Pin1 to pin3 “Open”:  
Fan, TEC or sensor failed
- Pin2 to pin3 “Open”:  
Normal
- Pin2 to pin3 “Close”:  
Fan , TEC or sensor failed

Part no. :

Delta model no. : HET200PC-B

### 3. Environmental conditions

#### 3-1. Operating temperature:

-40°C ~ +55°C (-40°F ~ 131°F)

#### 3-2. Storage temperature:

-40°C ~ +65°C (-40°F ~ 149°F)

#### 3-3. Humidity

External air circuit: 0 ~ 100% RH

Internal air circuit: 0 ~ 90% RH, Non-condensing

#### 3-4. Protection rating

IP55 (IEC60529) on external side with mounting on door.

#### 3-5. MTBF

Fan lifetime is expected to have a minimum L10 life of 80,000 hours continuous operation at 40°C with 15 ~ 65%RH at 48 voltage

### 4. Certified safety

#### 4-1. UL , CUL, CE , TUV



### 5. User cable

Each HET200PC-B will provide 1 cable with shipment.

#### 5-1 Power cable

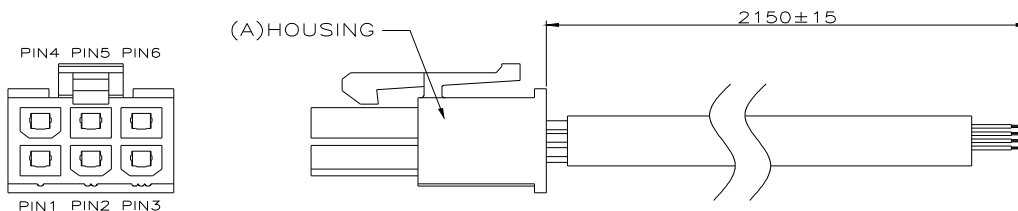

PINOUTS	CABLE WIRE COLOR	CABLE WIRE TYPE
CONNECTOR (A)		
(A) - PIN 1	BLACK	UL 1061 AWG#22
(A) - PIN 3	RED	
(A) - PIN 4	BLACK	
(A) - PIN 6	RED	

## 6. Warranty

Delta Electronics, Inc. warrants **one year (twelve months)** from the date of shipment , this warranty covers customer below application :

- Customer follows Delta specification to install and operate the product.
- The product and any parts do not be modified (including both mechanical and electrical modification) by customer themselves.

This warranty cover only repair, replacement or refund for defective Delta products does not include any loss of data or any costs associated with determining the source of system problems, costs for transportation, removal or reinstallation of equipment or labor for repairs or replacement made in the field.



## ***Application Notice***

- 1. Delta will not guarantee the performance of the products if the application condition falls outside the parameters set forth in the specification.**
- 2. A written request should be submitted to Delta prior to approval if deviation from this specification is required.**
- 3. Please exercise caution when handling fans. Damage may be caused when pressure is applied to the impeller, if the fans are handled by the lead wires, or if the fan was hard-dropped to the production floor.**
- 4. Except as pertains to some special designs, there is no guarantee that the products will be free from any such safety problems or failures as caused by the introduction of powder, droplets of water or encroachment of insect into the hub.**
- 5. The above-mentioned conditions are representative of some unique examples and viewed as the first point of reference prior to all other information.**
- 6. It is very important to establish the correct polarity before connecting the fan to the power source. Positive (+) and Negative (-). Damage may be caused to the fans if connection is with reverse polarity, if there is no foolproof method to protect against such error specifically mentioned in this spec.**
- 7. Delta fans without special protection are not suitable where any corrosive fluids are introduced to their environment.**
- 8. Please ensure all fans are stored according to the storage temperature limits specified. Do not store fans in a high humidity environment. We highly recommend performance testing is conducted before shipping, if the fans have been stored over 6 months.**
- 9. Not all fans are provided with the Lock Rotor Protection feature. If you impair the rotation of the impeller for the fans that do not have this function, the performance of those fans will lead to failure.**
- 10. Please be cautious when mounting the fan. Incorrect mounting of fans may cause excess resonance, vibration and subsequent noise.**
- 11. It is important to consider safety when testing the fans. A suitable fan guard should be fitted to the fan to guard against any potential for personal injury.**
- 12. Except where specifically stated, all tests are carried out at room (ambient) temperature and relative humidity conditions of 25°C, 65% RH. The test value is only for fan performance itself.**
- 13. Be certain to connect an “ 4.7 $\mu$ F or greater” capacitor to the fan externally when the application calls for using multiple fans in parallel, to avoid any unstable power.**